

Alpine

OVERHEAD DOORS, INC.

GENERAL
INSTALLATION
INSTRUCTIONS

BETWEEN JAMBS MOUNT; TYPE 1 & 4

Verify the clear opening dimensions & verify packing list for overall door width and check the markings on the pipe. They should match. Type 4 is generally used for the drive, tension or chainset side of the door.

Type 1 mounting is used in situations where an inside charge wheel is present due to limited side room. If both sides are Type 1 then generally such a door can be operated as a push up only. Level the mounting guide angles (using a water level) to insure that left and right mounting angles are plumb. Note that in the BETWEEN JAMBS condition, the mounting angles will be equal in height to the clear opening height.

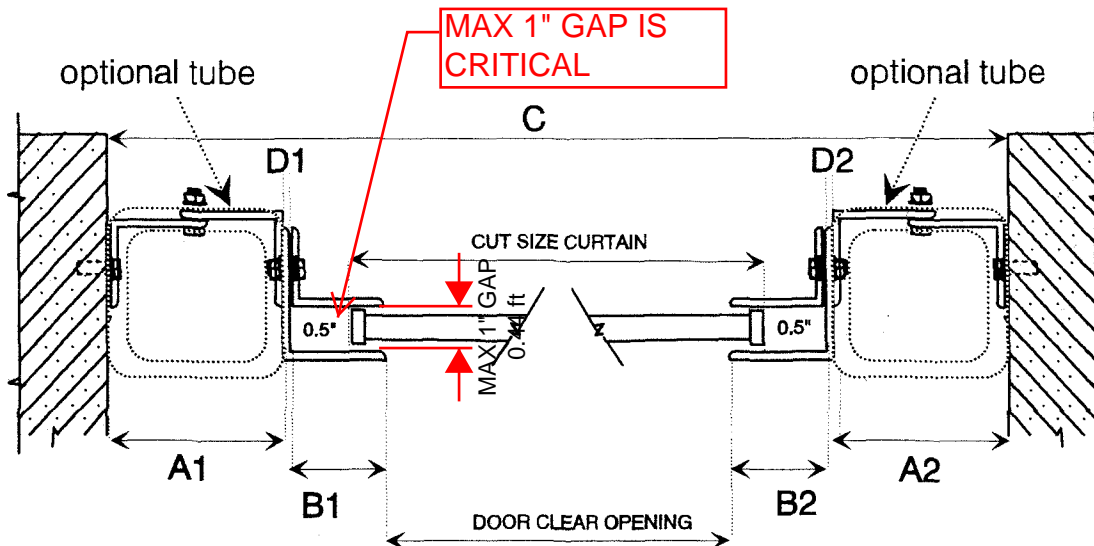
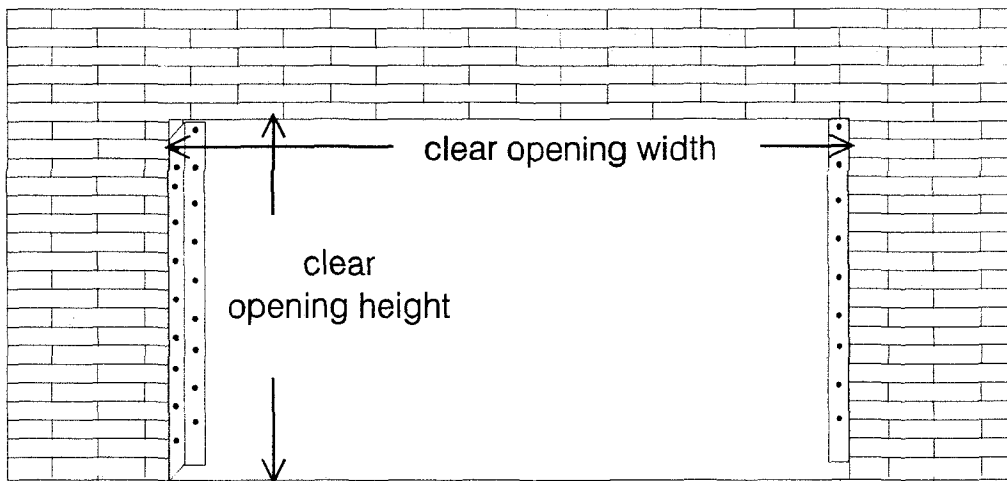
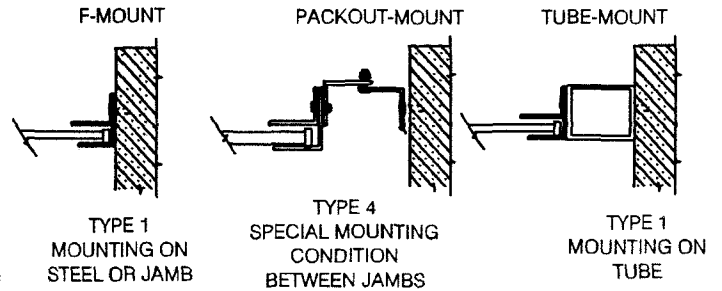

DOOR CLEAR OPENING= C-A2-A1-B1-B2 CUT SIZE CURTAIN=C-A2-A1-D1-D2-1"

Alpine[®]

OVERHEAD DOORS, INC.

GENERAL
INSTALLATION
INSTRUCTIONS

Mark mounting holes on wall, then use drill and set shields, or drill and tap into steel, or drill holes for the thru wall bolts. Note: It is recommended that you drill a hole at the top and bottom of the mounting angle first. Then set the angle on the wall. Repeat the same for the second mounting angle. Then proceed with the marking and drilling of the remaining holes.

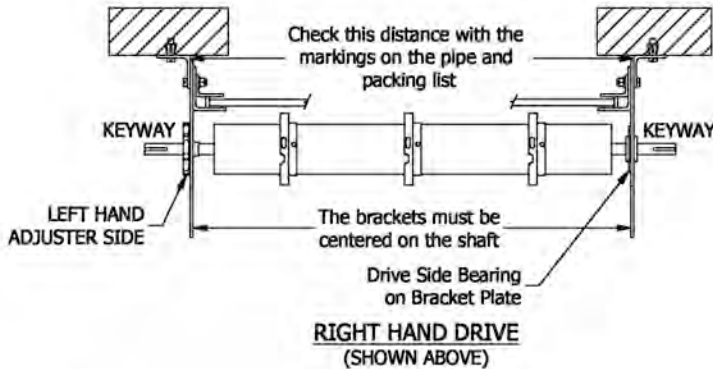

Remove pipe shaft and curtain from the packing case or crate; lay on the floor, as to "hand drive side" (left or right). Place the brackets on shaft and drive bracket on proper side. If motor operation - mount the drive sprocket to prevent the end bracket from coming off. Set screws. On the charge side mount the charging wheel. Note: on the drive side of the end bracket is a bearing. Set locking screws to prevent the end bracket from sliding. On the tension side DO NOT put a stop bar on the end bracket connecting to the charge wheel at this time. Leave it free to turn. It is important that the end brackets are centered on the pipe shaft.

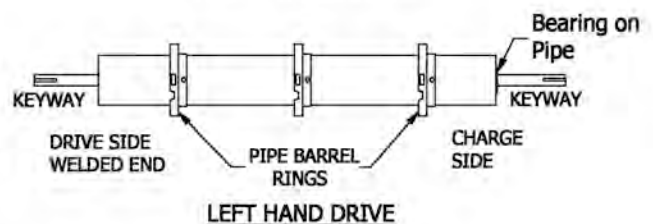
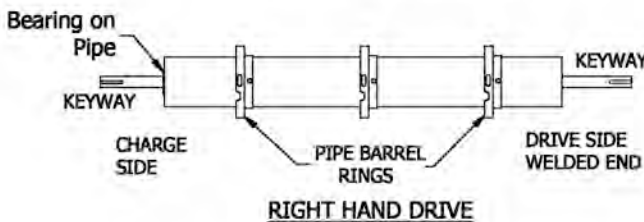

NOTE: PIPE BARRELS ARE ALWAYS PLACED ON SHAFT WITH WELDED FLANGE FACING RIGHT REGARDLESS OF WHETHER THE DOOR IS RIGHT OR LEFT HAND OPERATED (AS OF 2016)

Lift pipe shaft with attached end brackets to the top of the mounting angle and bolt end brackets to mounting angles. Set pipe shaft perfectly leveled. This will insure proper roll-up of the curtain. Once completed and dimensions are verified, and all bolts are secured with proper torque, you can proceed with the mounting of the curtain.

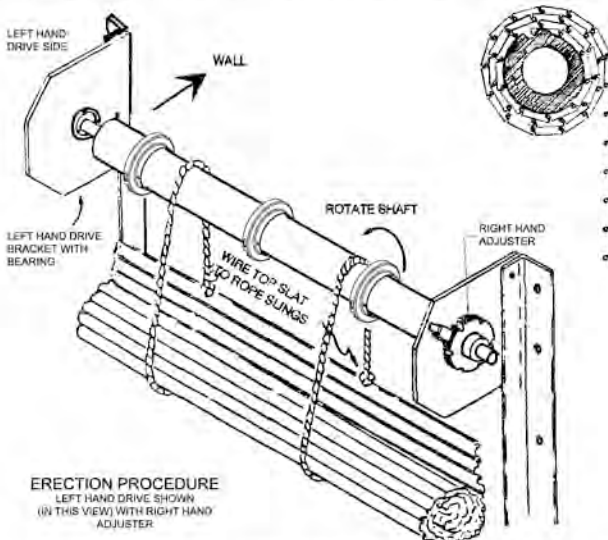

← Note: This is the proper way to install the curtain on the shaft.

Lift the rolled up curtain up to 1 foot below the mounted shaft, attach rope slings of adequate size around the curtain (on units 16 ft. or more use 3 or more rope slings), as shown on the left. Once the slings are in place drop the lift slightly putting minimum weight on the rope slings and pull the top slat up between the slings and the spring assembly matching the top slat holes with the holes in the pipe shaft or barrel rings. Fasten with bolts, nuts and washers provided but do not tighten. Adjust the top slat so that there is an equal distance between the edge of the endlock and the inside face of the bracket plates. Now permanently fasten the top slat to the pipe shaft or barrel rings. Remove lift so that all the curtain weight rests on the slings.

Alpine[®]

OVERHEAD DOORS, INC.

GENERAL INSTALLATION INSTRUCTIONS

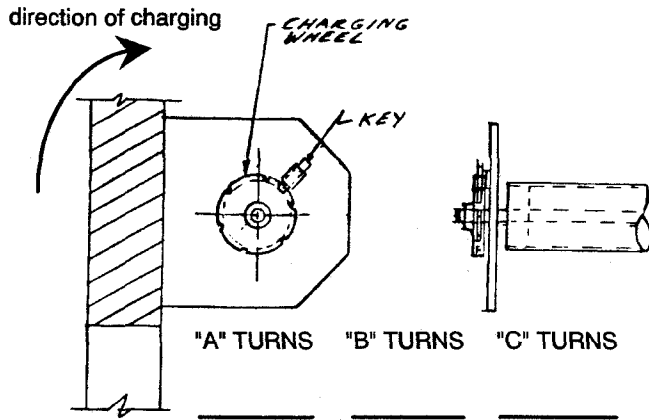

WARNING! Applying spring tension is dangerous. It requires two workers for safety. You will need two 1 1/2" x 1/4" flat bars, 18" long (not provided) to apply tension to the springs. Slide one of the bars into any of the six slots on the adjusting wheel. Wind in the direction the pipe would rotate when the door is going up (i.e. adjuster on the left - clockwise, adjuster on the right - counterclockwise.) Slide the second bar in the slot above, hold and remove the lower bar. Repeat the procedure until the curtain starts to coil around the spring assembly and stop when the bottom bar becomes visible. Line up the adjusting wheel slots with the channel stop and slide the stop bar (1" x 1/4" x 4" flat bar) provided through the channel and into the slot on the adjusting wheel. Remove the adjusting bar. After the pipe assembly is fully charged, place the bottom bar of the curtain into the guides and place bell mounts onto the guide tab with bolts provided. Final adjustments will be completed in a later step.

With the slings still in place for safety, fasten both guides with the bolt and nuts provided to the inside face of the wall angles. In all cases the flange faces to the wall and butts up against the bottom edge of the bracket plate.

Apply "A" turns for the initial charge while door is fully raised. The total charge when the door is closed is "B" turns, and the springs are designed to be elastic for "C" turns. Refer to the factory for values of A, B and C for your door.

The door should not drop when half open, nor should it pick up at the top and bottom. If it drops, the charge should be increased. If it picks up, the charge should be decreased.

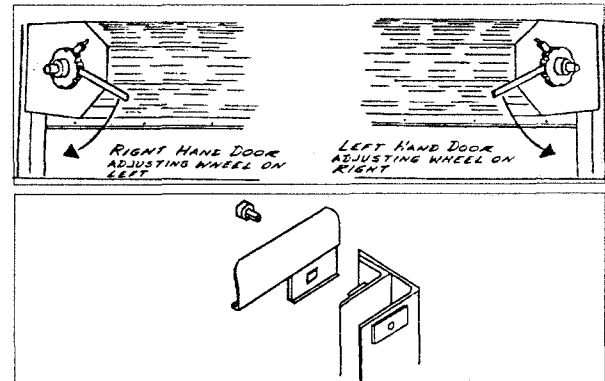

Attach the chain set or motor operator to the end bracket of the drive side. Be sure that everything is secured properly.

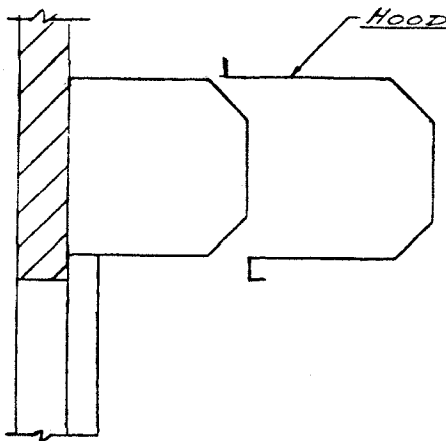

Install sheet metal hood by bolting it to the end brackets. Install additional sheet metal fascias and covers, if provided.

After a few months or a year, the adjustments of the springs at their anchorage to the door load may require a notch or two increase in the charge. A very slight pick up at the top and bottom may be permitted originally to avoid this adjustment.

The guides should be treated with a graphite greased.



GENERAL
INSTALLATION
INSTRUCTIONS

MAINTENANCE INSTRUCTIONS

LUBRICATION

The most important single maintenance item on doors of this type is lubrication. This is required only at certain points because all rotating members are equipped with high quality sealed bearings that are lubricated for life.

The curtain guides and the teeth of the gears contained in chain hoist or hand crank mechanism (if supplied) should be lubricated at least twice a year (more often if door works very frequently) with one of the following greases:

- Dixon's #2 Graphite Cup Grease (#1 for summer weather)
- Alemite MP Lithium Grease (#1 for winter weather, #2 for normal)
- Texaco #904 Graphite Grease, or other equivalents

If door is electrically operated, check the oil level in the worm gear speed reducer every six months and replenish if necessary with S.A.E. 140 gear oil for normally heated buildings or thinner grades for outside installations exposed to low temperatures.

PAINT:

All non-lubricated steel surfaces should be painted annually (more often if required in corrosive atmospheres) with a good grade of rust inhibiting metallic base paint.

SPRING ADJUSTMENT:

In time, the counter balancing springs may lose some of their initial tension; this condition imposes an extra load on the operator and should be corrected as follows.

- a) manually operated doors should be opened fully by hand and held open by "C" clamps or vise grip pliers on each guide.
- b) Mechanically operated doors should be opened fully and the crank or hand chain should be locked to hold the door open.
- c) electrically operated doors should be open fully by pushing the UP or OPEN button; motor brake will hold the door open. Shut off power supply to the motor during adjustment.
- d) with a suitable tool (18" or 24" pipe wrench or larger spanner) turn the spring adjusting wheel (1/8 turn at a time) until the door is balanced properly. Make sure locking pawl is properly engaged in spring adjusting wheel.

NOTE: For door with adjusting wheel on left hand side, wind spring clockwise (downward), for door with adjusting wheel on right hand side, wind spring counterclockwise (downward).