

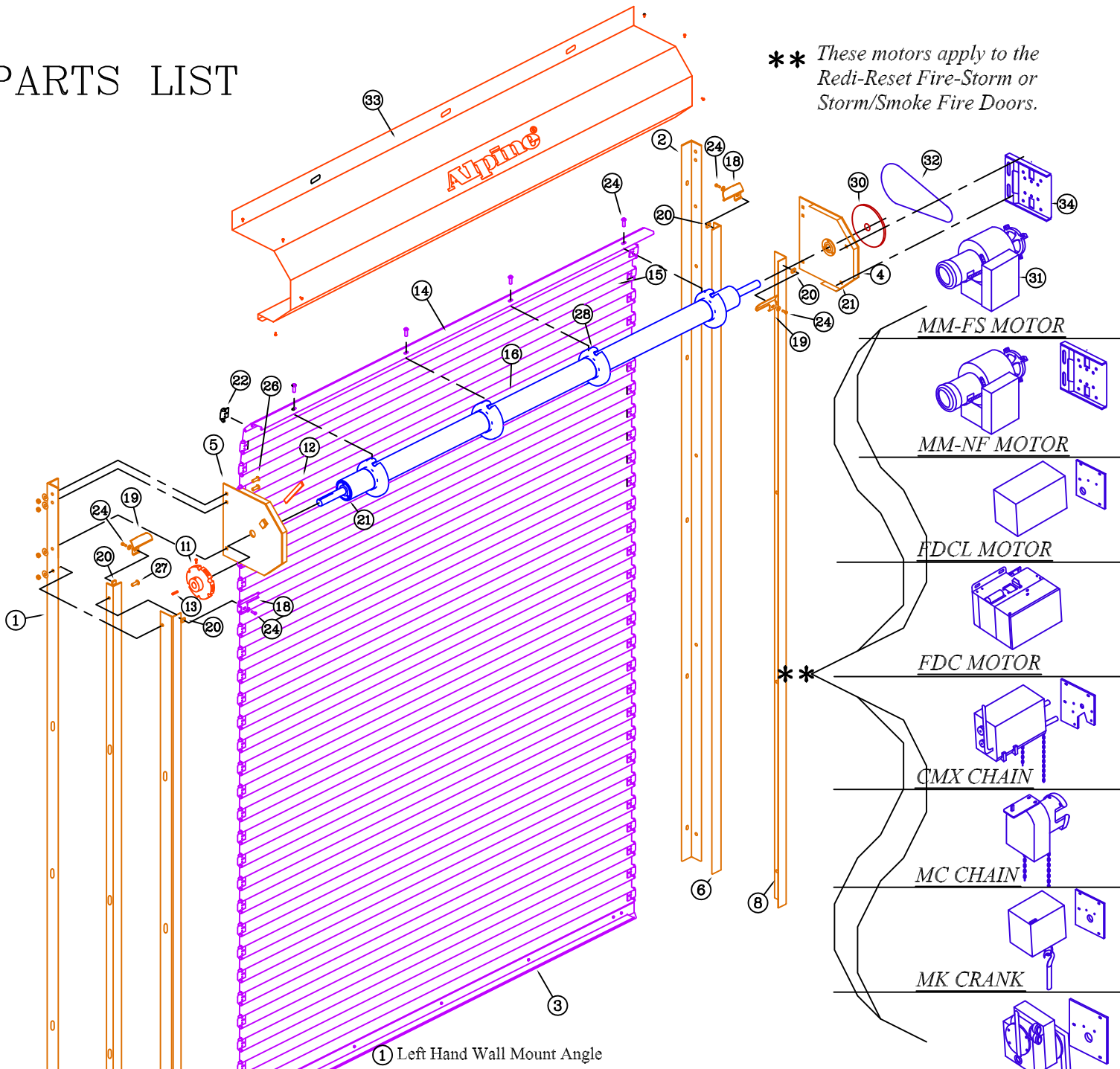

# PARTS LIST

\*\* These motors apply to the Redi-Reset Fire-Storm or Storm/Smoke Fire Doors.



- ① Left Hand Wall Mount Angle
- ② Right Hand Wall Mount Angle
- ③ Curtain Assembly
- ④ Drive Side Bracket Plate
- ⑤ Charge Wheel Side Bracket Plate
- ⑥ Right Hand Inner Guide Angle
- ⑦ Left Hand Inner Guide Angle
- ⑧ Right Hand Outer Guide Angle
- ⑨ Left Hand Outer Guide Angle
- ⑩ Wind bar 1/2" x 1/2"
- ⑪ Charge Wheel Key way & Set screw
- ⑫ Charge Wheel Tension Retainer Bar
- ⑬ Key way Stock
- ⑭ Starter Slat
- ⑮ Door Curtain
- ⑯ Counterbalance Barrel
- ⑰ Rubber Astragal
- ⑱ Left Side Bell Stopper
- ⑲ Right Side Bell Stopper
- ⑳ 1 1/2" x 1 1/4" x 5/16" Threaded Tab
- ㉑ 1 1/4" Bearing
- ㉒ Cast Iron Wind lock / End lock
- ㉓ 24 Galvanized Hood
- ㉔ 3/8" x 1/2" Hex Head Bolt w/ Washer
- ㉕ Rivets
- ㉖ 1/2" Carriage Bolt & Nut
- ㉗ 5/8" Bolt w/ Lock Washer & Nut
- ㉘ Collar (for 4" Barrel only)
- ㉙ #10 Screw
- ㉚ Drive Gear or Sprocket
- ㉛ Motor Operator (Optional)
- ㉜ Roller Chain (Optional for use with Motor Doors)
- ㉝ Hood
- ㉞ Operator Mounting Plate

**MM-FS MOTOR**

**MM-NF MOTOR**

**FDCL MOTOR**

**FDC MOTOR**

**CMX CHAIN**

**MC CHAIN**

**MK CRANK**

**GC CHAIN**

Notes:

1. Read all instructions carefully, checking shop drawings supplied for any special conditions. Open all crated materials and check for damaged or missing parts prior to installation. If any damaged occurred you must notify your carrier immediately.
2. Left hand (LH) or right hand (RH) is taken as you face the door opening from the coil side of the unit. Also, you may have to disassemble the guide assembly and use the wall mounting angles to first mount them on the wall, you have the option to change from the E-mount guide, reverse it for the Z-mount guide.

**Inspection:**

Establish opening width and height and check against the opening size shown on the shop drawings. Level the sill surface that the door wall angle or tube will rest on.

**Installing wall mounting angles:** (refer to figure 2-A , B, C & D)

- FIRST: Set Left hand wall mount angle in place according to figure 2-B (OGW) and plumb. Make sure that the OFW (Overall Fame Width) distance, plus drive sprocket and charge wheel have clearance.
- SECOND: Mark the hole location on the wall and remove the wall mounting angles.
- THIRD: Drill and prepare holes for wall fasteners.
- FOURTH: Return the wall mount angle into position and install with wall fasteners, securing angle into place. The galvanized or fiber washers must be installed (refer to the wall fastener washer detail).
- FIFTH: Measure from the LH wall angle the distance between the wall angle and make a reference mark for locating the RH wall angle.
- SIXTH: Place the RH guide assembly on the reference mark, plumb and level with respect to the LH guide assembly.
- SEVENTH: Repeat steps 2 through 4 for the RH guide assembly.

*Note: Alpine Overhead doors are manufactured to close tolerances. It is important that the cow guides are positioned at the proper distance between guides, and that both angles are plumb and level.*

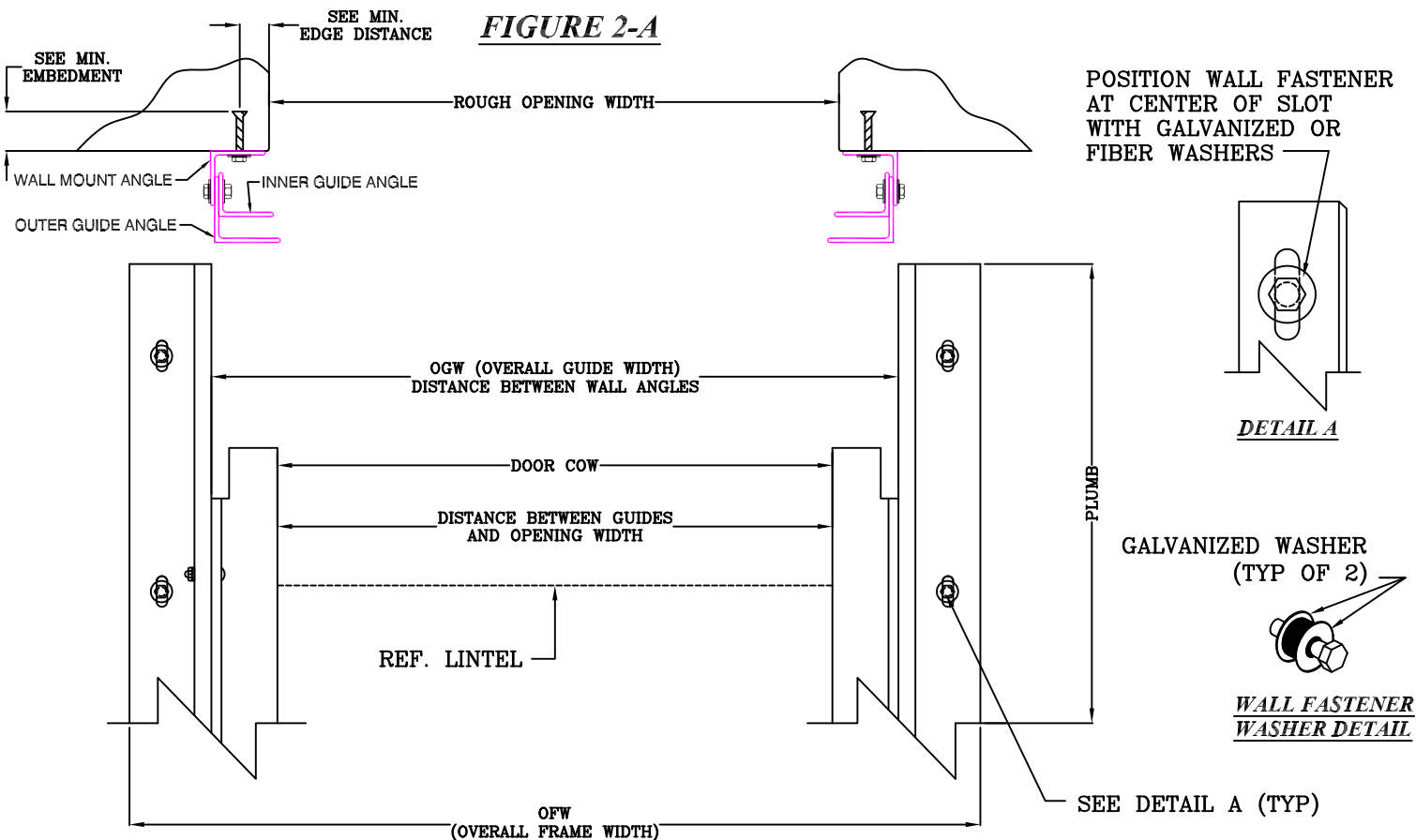

**FIGURE 2-B**

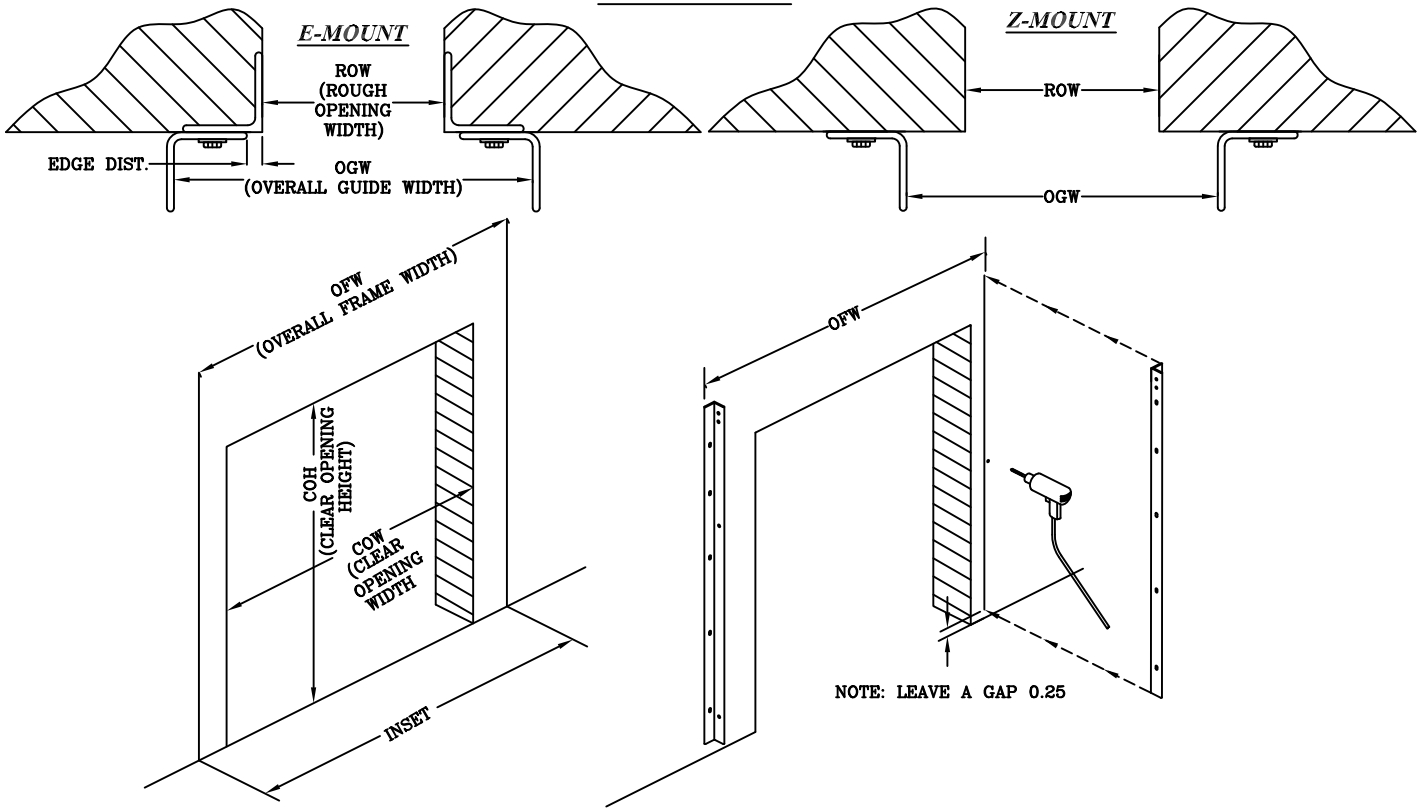

**Removing mounting angles:**

FIRST: Drill and set shields, drill and tap into steel or drill for through wall bolts (use appropriate mounting for field conditions). Install fasteners, nuts and galvanized washers.

SECOND: For high wind zones (HVHZ) refer to approved shop drawings for proper mounting conditions.

*Note: For (HVHZ) doors over 10 feet wide, it is recommended that a steel channel frame be provided as an integral part of the building structure to accept an "E-Mount" configuration.*

THIRD: Fasten mounting angles to the wall. Use the same procedure on the opposite side of opening. Make sure the angles are square and plumb to the opening.

**FIGURE 2-C**

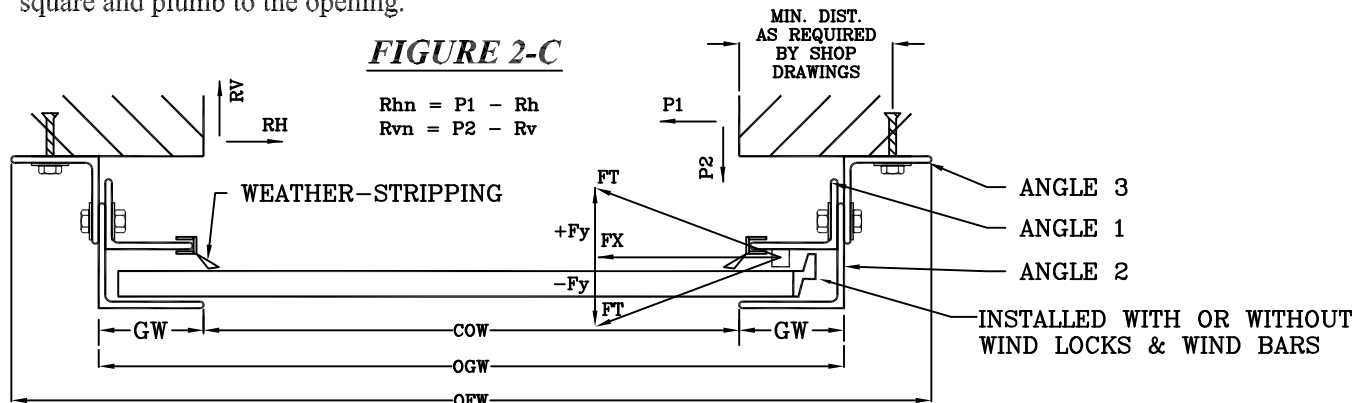

**GUIDE SECTION**

| CLEAR OPENING |          | OVERALL GUIDE | UNDER BRACKET | OVERALL FRAME |          |
|---------------|----------|---------------|---------------|---------------|----------|
| COWIDTH       | COHEIGHT | OGWIDTH       | UBHEIGHT      | OFWIDTH       | OFHEIGHT |



**FIGURE 2-D**

Level & Plumb

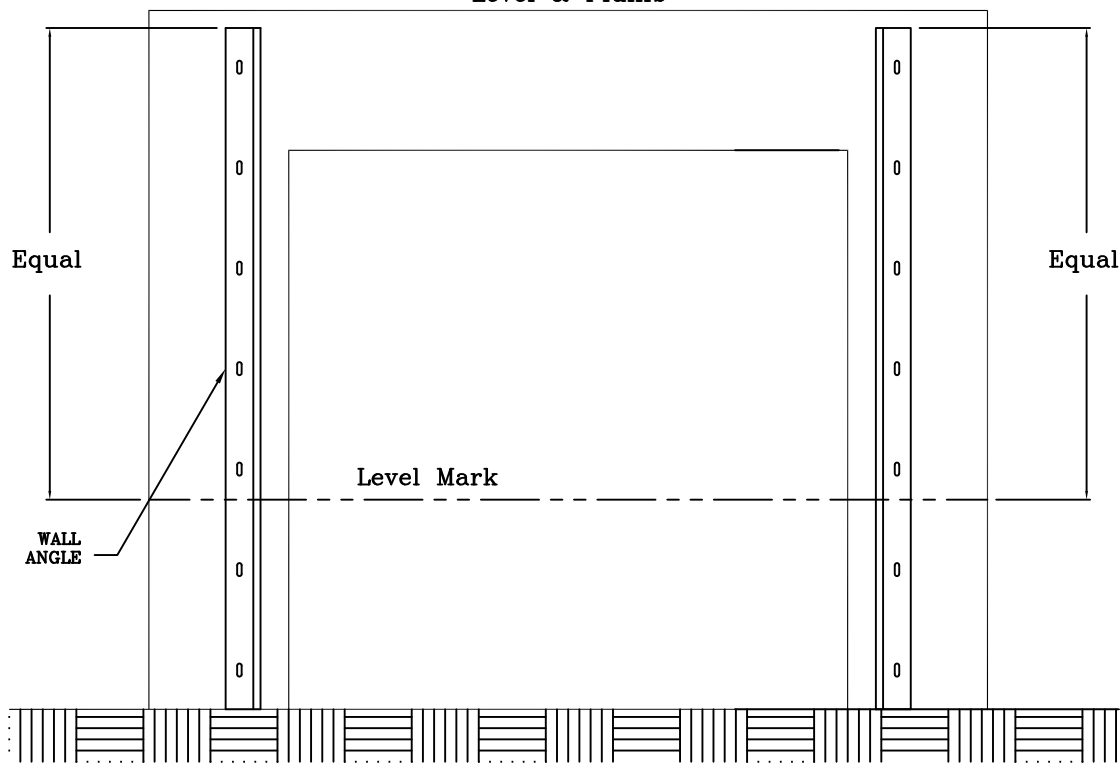

*Note: The drive assembly is not balanced when lifting. Use caution, as the tension side will be much heavier than the drive side.*

**Installing barrel and head plates:**

FIRST: lock bushing with set screw as shown in figure 2-E. Must be set to stop barrel movement (both left to right, and side to side). Note: Barrel deflection shall not to exceed .03 inches per foot of width. Bracket not less than 8".

**FIGURE 2-E**

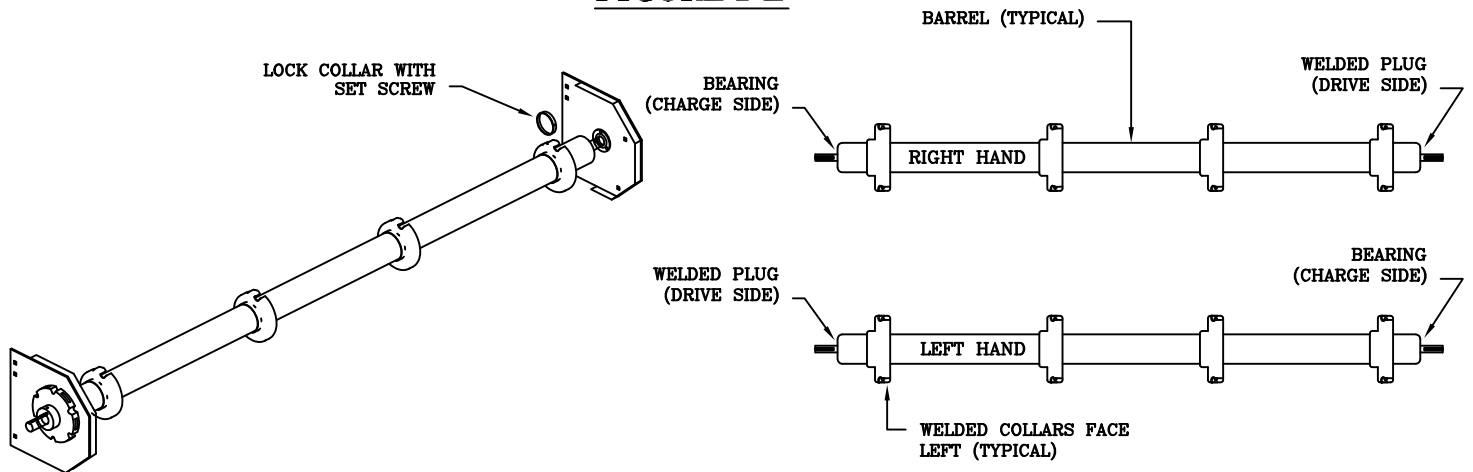

SECOND: Remove pipe shaft and curtain from package or crate; place on level ground (flat and free of debris), as to "drive side" orientation (right or left as in figure 2-E). Install locking collar on the inner shaft, between the pipe and bracket plate with bearing (unless bearing has locking set screws). Place brackets on shaft with drive side bracket on proper side. (see Figure 2-E). Mount the drive gear or sprocket to prevent the bracket from coming off. Install charge side bracket on other end of the shaft, then the charge wheel and key way to shaft. **DO NOT PUT A TENSION RETAINER BAR THROUGH THE CHANNEL, INTO THE CHARGE WHEEL AT THIS TIME.** Leave it free to turn. Torque set screws to center the barrel according to steps outlined in figure 2-E.

**THIRD:** Lift pipe barrel with attached end brackets (figure 2-E) to the top of the wall mounting angles and bolt end brackets to mounting angles. Set pipe shaft level (within 1/16"). This is to ensure proper roll-up of the curtain. Once completed, dimensions are verified and all bolts are torque, Proceed to mounting the curtain.

*Note: Never lift with a single support or exceed 4 feet overhang while lifting, loading, unloading or transporting the curtain assembly. This will cause damage (DO NOT lift with fork lift, without sling or pads under forks.*

### Installing curtain:

**FIRST:** Lift the rolled up curtain 12"-24" below the mounted shaft, attach rope slings of adequate size around the curtain, (figure 3). Once the slings are in place, drop the lift below, approximately 1" under the rope slings for safety. Pull slat up between the top slings and the pipe barrel matching the holes with the pipe barrel. Note: Pipe barrel may have tapped holes, tapped tabs or barrel rings. Fasten curtain with the hardware provided but do not tighten. Center and level the curtain assembly to the pipe barrel and secure and torque all fasteners. Remove lift so that the curtain weight rests on the slings.

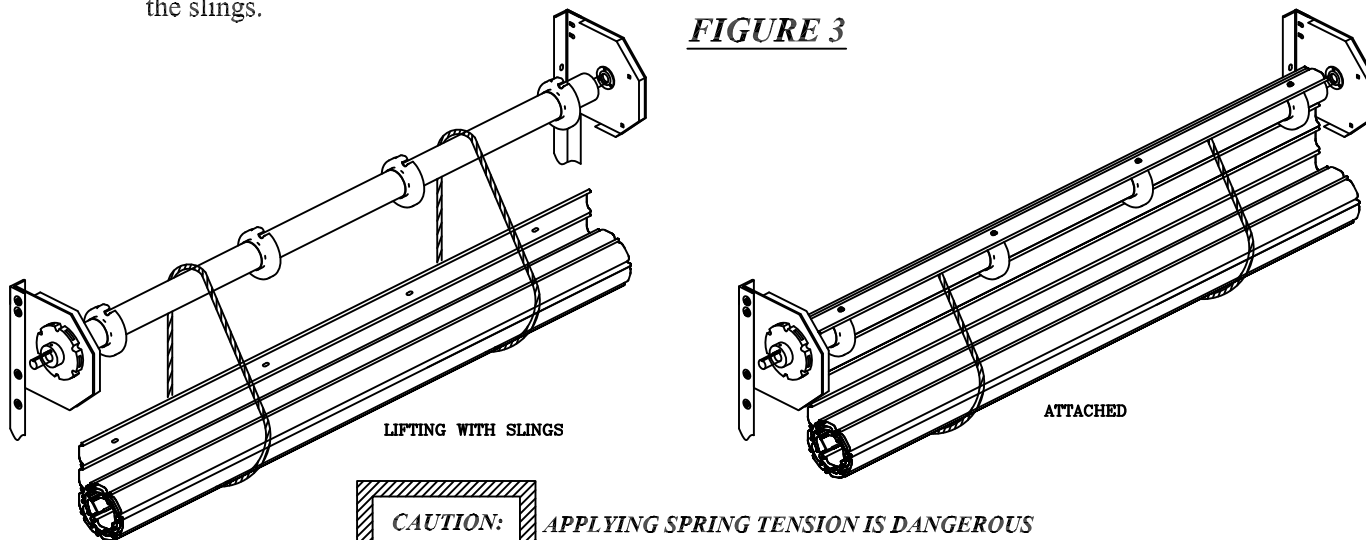

**CAUTION:**

**APPLYING SPRING TENSION IS DANGEROUS**

**SECOND:** It requires two workers for safety. You will need two 1 x 1/4 flat bars, min. 18" long (not provided) to apply tension to the springs. Slide one of the bars into any of the slots of the charge wheel. Rotate in the direction that the door would roll up (charge wheel on left; clockwise, charge wheel on right; counterclockwise) (see figures 3 & 4). Slide the second bar in the slot above, hold and remove the lower bar. Repeat the procedure until the curtain starts to coil around pipe barrel and stop when the bottom bar becomes visible. Line up the charge wheel slots with the channel stop on the charge bracket and slide the tension retainer bar provided, through the slot on the charge wheel.

**CAUTION:**

**DO NOT REMOVE SLINGS AT THIS TIME FOR SAFETY**

**FIGURE 4**

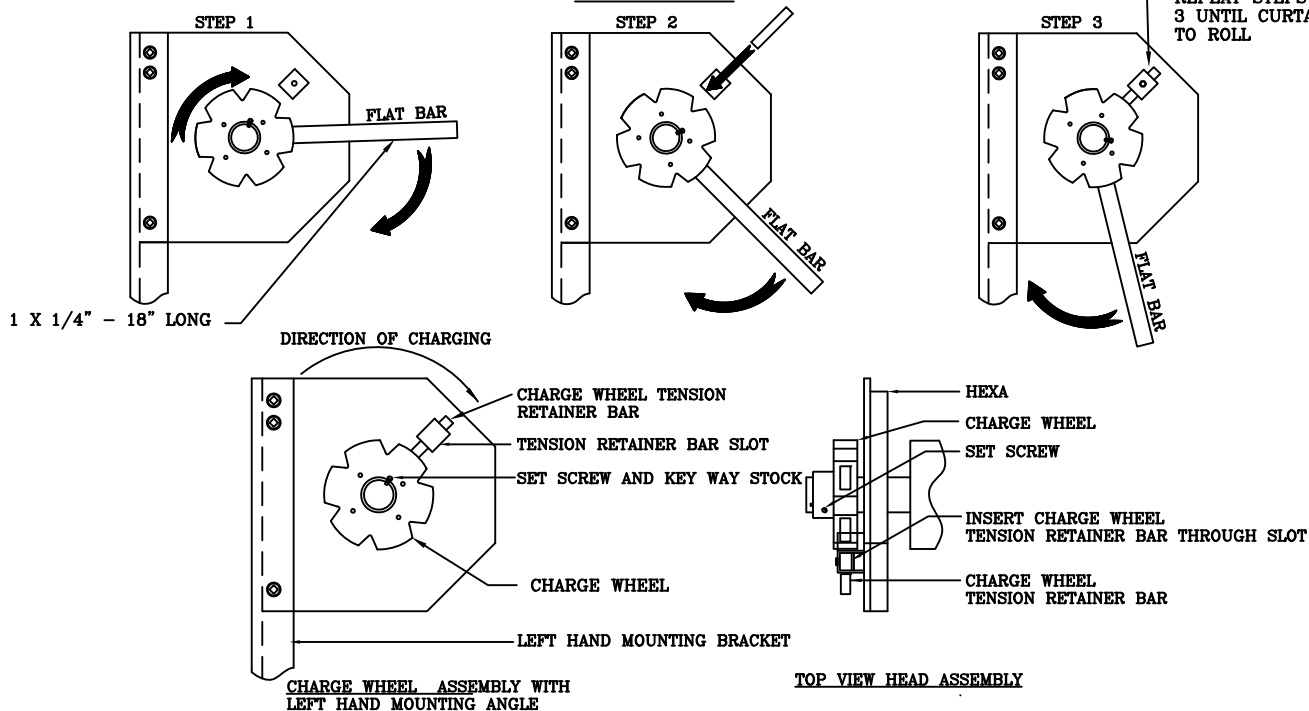

## Installing inner and outer guide angles:

FIRST: Leave slings in place and install all inner and outer guide angles onto the wall mounting angles, both left and right side. Measure proper guide space to allow curtain to ride freely in the guide rails.

**FIGURE 5**

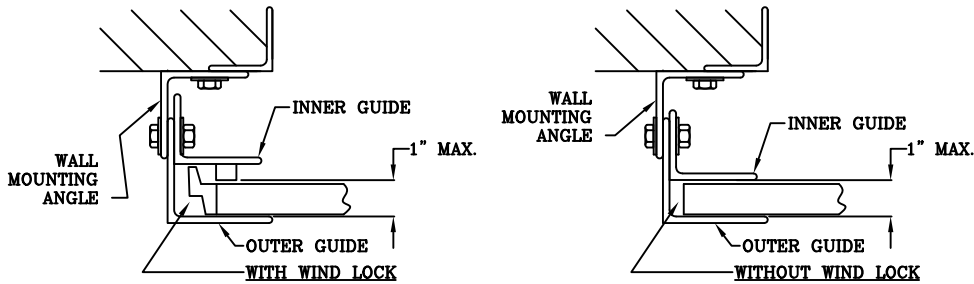

*Note: For high wind zones (HVHZ) refer to approved shop drawings for proper mounting conditions.*



**GUIDE SPACE SHOULD NOT EXCEED 1" OR WIND LOCKS MAY NOT ENGAGE PROPERLY. (SEE FIGURE 5)**

**FIGURE 6**

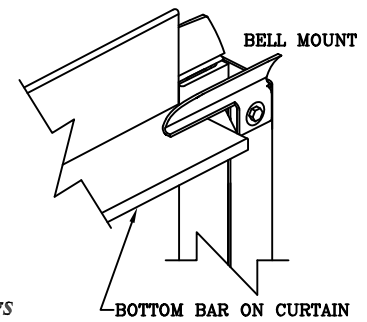

SECOND: Now that the guide assemblies are fastened and secured, the curtain must be fully rolled up and the bottom bar engaged to bell mount stops (figure 6). Test and adjust for proper balance at the header at this time, with slings still in place to prevent curtain falling.

THIRD: Attach the chain set, crank or motor operator to the end bracket of the drive side. Be sure that everything is secured properly then remove rope slings (place "C" clamps in guides to prevent curtain from falling during removal of rope slings).

*Special Note: Alpine's doors are fully balanced when installing. After installing the operator, the installer must remove open weight charge tension to allow door to close on Redi-reset operators.*

## Installing motor connections: (Refer to Operator Installation Instructions via chain crank or motor)

FIRST: Connect power supply to motor according to the wiring diagram.

SECOND: Mount the push button control station within sight of the unit and attach wiring according to the wiring diagram.

THIRD: Connect the central alarm (if applicable) to the operator according to the wiring diagram.

FOURTH: Adjust the motor travel limit switched as described in the motor installation instructions.

FIFTH: After all connections are complete and the limits are set, operate the unit to the open position.

SIXTH: On all motor operated units, set roller chain tension properly. Half links are used for fine adjustment. Motor operators that have excessive vibration must be braced diagonally to wall or adjacent construction. Be certain that the operator is firmly mounted.

SEVENTH: Install hood, soffits, special covers and any special hardware furnished (see figure 6-A) Install center hood support if supplied. Caulk exterior hoods.

**FIGURE 6**

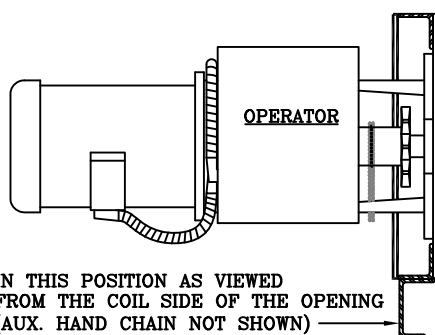

**FIGURE 6-A**

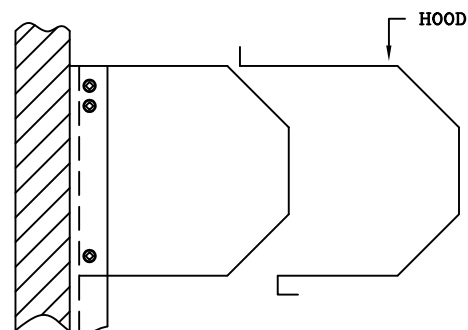

## **Final adjustments to spring tension:**

FIRST: With the unit in the full open position, rotate the charge wheel (see figure 4) by hand in a direction approximately  $\frac{1}{4}$  turn until a slight resistance is felt. Insert the charge wheel tension retainer bar through the slot on the charge wheel side bracket plate and into the slot on the charge wheel. Refer to Figure 4.

**FIGURE 4**

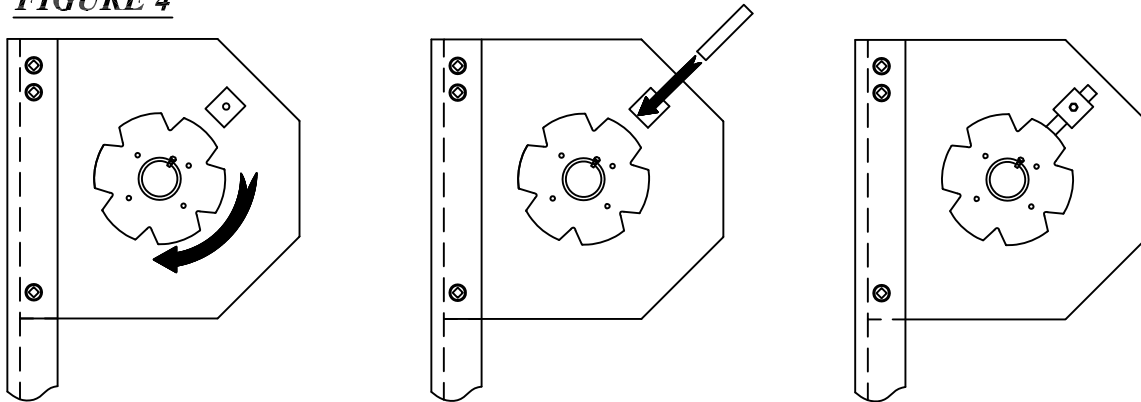

### **NOTE**

After a few months or a year, the adjustments of the charge wheel and the anchorage to the door components, may require inspection and maintenance. An additional pick up at the top and bottom may be permitted originally to allow for a "breaking-in" period to minimize additional tension that may be required.

The guides should be treated with a silicone or synthetic based lubricant (see maintenance instructions on page 8 for details). When all electric wiring is completed and fuseable links are set in place.

### **NOTE**

ON REDI-RESET FIRE/SMOKE DOOR'S OPERATOR, THE FINAL TENSION IS COMPLETE, WHEN THE DOOR IS IN THE OPEN POSITION. WITH DOOR IN OPEN POSITION INSTALLER MUST REMOVE ALL TENSION FROM THE CHARGE WHEEL AND TEST THE DOOR CLOSING. "CONTROLLED" IS BETWEEN 6" TO 24" PER SECOND. IMPORTANT: NOT LESS THAN 6" PER SECOND AND NOT MORE THAN 24" PER SECOND. MAY REQUIRE REVERSE TENSION IF THE DOOR DOES NOT CLOSE ON GRAVITY DURING TESTING.



OVERHEAD DOORS, INC.

Patent # 5657805

**REDI-STORM™**

HURRICANE PROTECTION DEVICE  
APPROVED MEANS OF EGRESS

## LUBRICATION:

### MAINTENANCE INSTRUCTIONS

The most important single maintenance item on doors of this type is lubrication. This is required only at certain points because all rotating members are equipped with high quality sealed bearings that are lubricated for life.

The curtain guides and the teeth of the gears contained in the chain hoist or hand crank mechanism (if supplied) should be lubricated at least twice a year (more often if the door works very frequently) with one of the following greases:

- Dixon's Graphite Cup Grease (#1 for normal weather, # 2 for winter weather)
- Alemite MP Lithium Grease (#1 for winter weather, # 2 for normal weather)
- Texaco #904 Graphite Grease, or other equivalents

If door is electrically operated, check the oil level in the worm gear speed reducer every six months and replenish if necessary with S.A.E. 140 gear oil for normally heated buildings or thinner grades for outside installations exposed to low temperatures.

## PAINT:

All non-lubricated steel surfaces should be painted annually (more often if required in corrosive atmospheres) with a good grade of rust inhibiting metallic based paint. If the door is powder coated, touchup paint can be obtained by a local paint supplier.



**APPLYING SPRING TENSION IS DANGEROUS. ONLY  
EXPERIENCED DOOR INSTALLERS SHOULD PERFORM  
ADJUSTMENTS.**

## SPRING ADJUSTMENT:

In time, the counter balancing springs may lose some of their initial tension. This condition imposes an extra load on the operator and should be corrected as follows:

- The door must be raised to the full open position and held open by "C" clamps or vise grips on each guide.

*Note: If Electric operator is present, shut off main power supply during adjustment.*

- With suitable tool (18" or 24" pipe wrench or larger spanner) turn the spring adjusting charge wheel one notch at a time. Test door between additional notches, until the door is balanced properly. Use caution not to over tension, otherwise it will shorten the life cycle of the spring.

*Note: To add tension, turn in the direction that the door rolls up (charge wheel on left - clockwise, charge wheel on right - counterclockwise) (see figure 4).*

- Make sure tension retainer bar is properly engaged in spring adjusting charge wheel at all times.
- May require reverse tension if the door does not close on gravity during testing.



## TROUBLESHOOTING MANUAL FOR ROLLING STEEL DOORS.

### **Purpose:**

The following troubleshooting guidelines have been specifically written to provide a reliable source of information to all customers and users of Alpine Overhead Doors, Inc. rolling steel doors. This information will provide solutions to the most common problems and establishes a systematic sequence required in repairing a rolling steel door.

If a problem is encountered and it is not covered in this manual, kindly call Alpine sales representatives, for they are ready to assist you if you require further technical assistance.

### **Barrel:**

**Problem:** As the door is in the downward travel, it binds.

Causes:

- Curtain binds in guides.
- Bolts used to connect the curtain to the barrel are too long.
- Insufficient initial stretch of the tension spring or incorrect hand of the spring.
- Incorrect spring assembly for the opening.

Corrections:

- Increase the guide opening. Curtain must be loose in the guides.
- Replace the bolts with a shorter bolt.
- Consult the factory.
- Check the door mark on the barrel. Locate the correct barrel.

**Problem:** Tension wheel turns freely.

Causes:

- Spring broken.
- Broken shaft pin.
- Broken barrel pin.

Corrections: a. Items a through c, consult the factory.

**Problem:** Difficult to apply tension in adjusting the charge wheel.

Causes:

- Incorrect spring connection to the spring holders.
- Incorrect distance between the spring castings.
- Screws connecting the curtain or collar are too long.

Corrections: a. Items a through c, consult the factory.

**Problem:** Drive shaft crooked.

Causes: a. Broken weld or shipping damage.

Corrections: a. Consult the factory. Possible End Plug replacement.

### **Curtain:**

**Problem:** Curtain rolls up unevenly.

Causes:

- Top slat not in line.
- Tapped holes in barrel not on centerline.
- Barrel not level.
- Collar assembly improperly aligned.
- Damaged slats in curtain.

Corrections:

- Loosen top screws and straighten the curtain.
- Drill and tap the barrel with holes on centerline.
- Use hydro level to level the barrel.
- Consult the factory.
- Replace damaged slats.

## **Curtain: (continued)**

**Problem:** Curtain slats separate.

Causes: a. Freight damages.

Corrections: a. Replace the curtain.

**Problem:** Curtain separates from the barrel.

Causes: a. Curtain does not have 1/2" wrap on the barrel when in the closed position.  
b. Bolts pulled through the top slat.  
c. Interlocks not installed on the motor operated door.

Corrections: a. Insert additional slats in the curtain of the door.  
b. Install washers under the head of the bolts.  
c. Install interlocks to prevent motor operation when the door is locked.

**Problem:** Curtain appears to sag at the center.

Causes: a. Center of the curtain is against the barrel, the edge of the curtain is pulled toward the lintel as it enters the guides.  
b. Barrel deflection on wide doors.  
c. Starter slats improperly aligned to the barrel.

Corrections: a. Curvature of the curtain makes it appear to be sagging while it is actually level.  
b. Consult the factory.  
c. Remove the starter slat and allow for camber, then tighten.

## **Bottom Bar:**

**Problem:** Bottom bar interferes with the vinyl flap weatherstripping.

Causes: a. Incorrect guide opening.  
b. Incorrect cope on bottom bar angle.

Corrections: a. Increase guide openings.  
b. Increase cope to clear the weatherstripping.

**Problem:** Safety edge not working.

Causes: a. Open circuit in the bottom bar. Confirm by disconnecting wiring at the bottom bar and insert a continuity tester.  
b. Open circuit in coil cord or cord reel. Confirm by inserting a voltmeter into the plug. Reading should be 24 VAC.  
c. Door located in extremely wet or flooded environment.

Corrections: a. Replace the Safety edge.  
b. Replace the coil cord or cord reel.  
c. Eliminate the water and replace the Safety edge.

**Problem:** Locks inoperative.

Causes: a. Key slot of cylinder must be in the horizontal position.  
b. Damaged internal components.

Corrections: a. Reposition the cylinder and firmly secure with small screws into the bottom bar.  
b. Remove the bottom bar from the guide. Replace the locking mechanism.

**Problem:** Electrical interlocks inoperative.

Causes: a. Magnet on lock bolt does not line up with proximity switch on the guide.

Corrections: a. Adjust the proximity switch location where it is mounted to the guides.

## **Hood:**

**Problem:** Hood bends do not align with the end brackets.

Causes: a. Incorrect hood size.

Corrections: a. Accurately check all dimensions of material supplied and consult the factory.

## **Bracket:**

**Problem:** Brackets not perpendicular to the barrel.

Causes: a. Wall mount angle not square.

Corrections: a. Brace bracket into position and square.

## **Curtain: (continued)**

**Problem:** Curtain slats separate.

Causes: a. Freight damages.

Corrections: a. Replace the curtain.

**Problem:** Curtain separates from the barrel.

Causes: a. Curtain does not have 1/2" wrap on the barrel when in the closed position.  
b. Bolts pulled through the top slat.  
c. Interlocks not installed on the motor operated door.

Corrections: a. Insert additional slats in the curtain of the door.  
b. Install washers under the head of the bolts.  
c. Install interlocks to prevent motor operation when the door is locked.

**Problem:** Curtain appears to sag at the center.

Causes: a. Center of the curtain is against the barrel, the edge of the curtain is pulled toward the lintel as it enters the guides.  
b. Barrel deflection on wide doors.  
c. Starter slats improperly aligned to the barrel.

Corrections: a. Curvature of the curtain makes it appear to be sagging while it is actually level.  
b. Consult the factory.  
c. Remove the starter slat and allow for camber, then tighten.

## **Bottom Bar:**

**Problem:** Bottom bar interferes with the vinyl flap weatherstripping.

Causes: a. Incorrect guide opening.  
b. Incorrect cope on bottom bar angle.

Corrections: a. Increase guide openings.  
b. Increase cope to clear the weatherstripping.

**Problem:** Safety edge not working.

Causes: a. Open circuit in the bottom bar. Confirm by disconnecting wiring at the bottom bar and insert a continuity tester.  
b. Open circuit in coil cord or cord reel. Confirm by inserting a voltmeter into the plug. Reading should be 24 VAC.  
c. Door located in extremely wet or flooded environment.

Corrections: a. Replace the Safety edge.  
b. Replace the coil cord or cord reel.  
c. Eliminate the water and replace the Safety edge.

**Problem:** Locks inoperative.

Causes: a. Key slot of cylinder must be in the horizontal position.  
b. Damaged internal components.

Corrections: a. Reposition the cylinder and firmly secure with small screws into the bottom bar.  
b. Remove the bottom bar from the guide. Replace the locking mechanism.

**Problem:** Electrical interlocks inoperative.

Causes: a. Magnet on lock bolt does not line up with proximity switch on the guide.

Corrections: a. Adjust the proximity switch location where it is mounted to the guides.

## **Hood:**

**Problem:** Hood bends do not align with the end brackets.

Causes: a. Incorrect hood size.

Corrections: a. Accurately check all dimensions of material supplied and consult the factory.

## **Bracket:**

**Problem:** Brackets not perpendicular to the barrel.

Causes: a. Wall mount angle not square.

Corrections: a. Brace bracket into position and square.