



8 HULSE ROAD, EAST SETAUKET, NY 11733
TEL (631) 473-9300 FAX (631) 642-0800

TECHNICAL DATA SHEET

Introduction:

Rolling steel fire door manufacturers have noticed an increase in the demand for such fire doors to be installed on 3-hour non-masonry walls. The industry has learned that some of the jambs on masonry and non-masonry walls have not been suitable for mounting fire door guides to the jambs. In many instances, the jambs have not been designed to hold the load imposed by the rolling steel fire door. In October of 2000, DASMA sponsored a test of a rolling steel fire door mounted on steel tubes set against a 3-hour non-masonry wall. This Technical Data Sheet, based on the results of the testing, presents the concept of connecting steel tubes to the floor/sill and also to the wall above the opening or to a building's structural ceiling framing. The steel tubes themselves are not fastened to the wall. A steel tube is designed to fit over a base plate assembly, which is fastened to the floor/sill. The top-of-tube assembly secures the tube to the structural roof joists or slab above. On masonry walls, the top-of-tube assembly may be through-bolted in the wall. There is a slip fit between the top-of-tube assembly and the steel tube to provide tube expansion during a fire emergency. Information on steel tube size, steel tube thickness, base plate assembly and top-of-tube assembly can be found in the fire door manufacturer's UL and FM procedures.

Objectives:

The objectives of preparing the set of enclosed details are:

1. To show the basic concepts in a generic way, without being manufacturer-specific regarding details.
2. To show the three-angle guide and the four-angle guide options.

Attachment Contents:

- Figure 1: "E" mounted guide configuration; exposed steel tube
- Figure 2: "Z" mounted guide configuration; exposed steel tube
- Figure 3: Exposed tube mount detail, showing top of tube mount to ceiling
- Figure 4; Exposed tube mount detail, showing top of tube mounted to masonry wall via top-of-tube assembly
- Figure 5: Exposed tube mount detail, showing top of tube mounted to masonry wall via top-of-tube sleeve

TECHNICAL DATA SHEET

ROLLING STEEL FIRE DOORS BOLTED ONTO STEEL TUBES, SET AGAINST FACE OF FIRE RATED WALLS

General Notes:

1. Existing wall construction covered.
2. Details are for general information only. See manufacturer's installation instructions.
3. Consult a structural engineer for actual wall construction.
4. Details are attached to TDS-273.
5. Details apply to masonry, drywall and sodium silicate walls.
6. Steel tubes cannot be mounted between jambs.

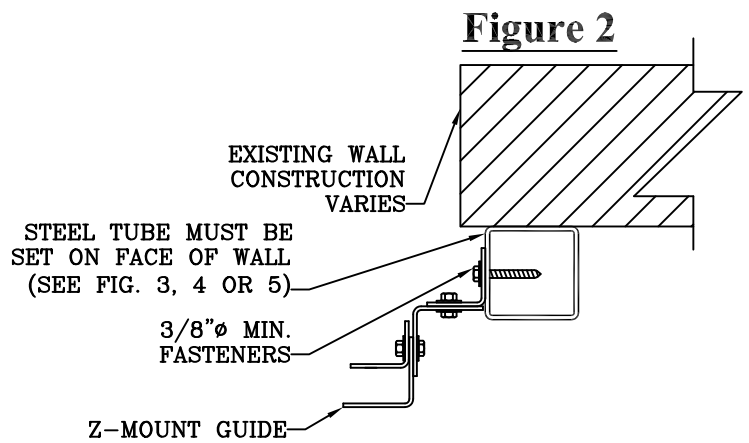
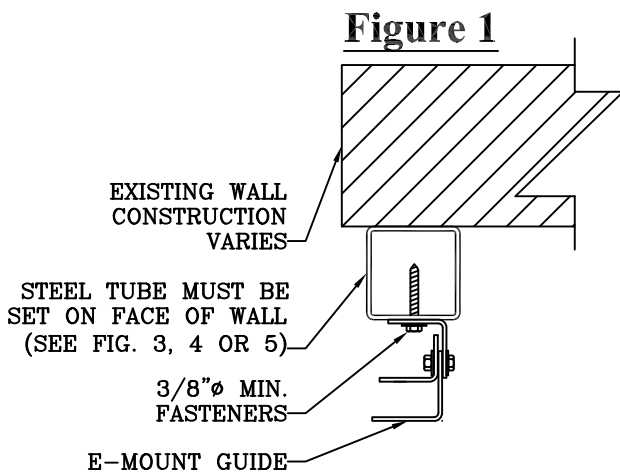
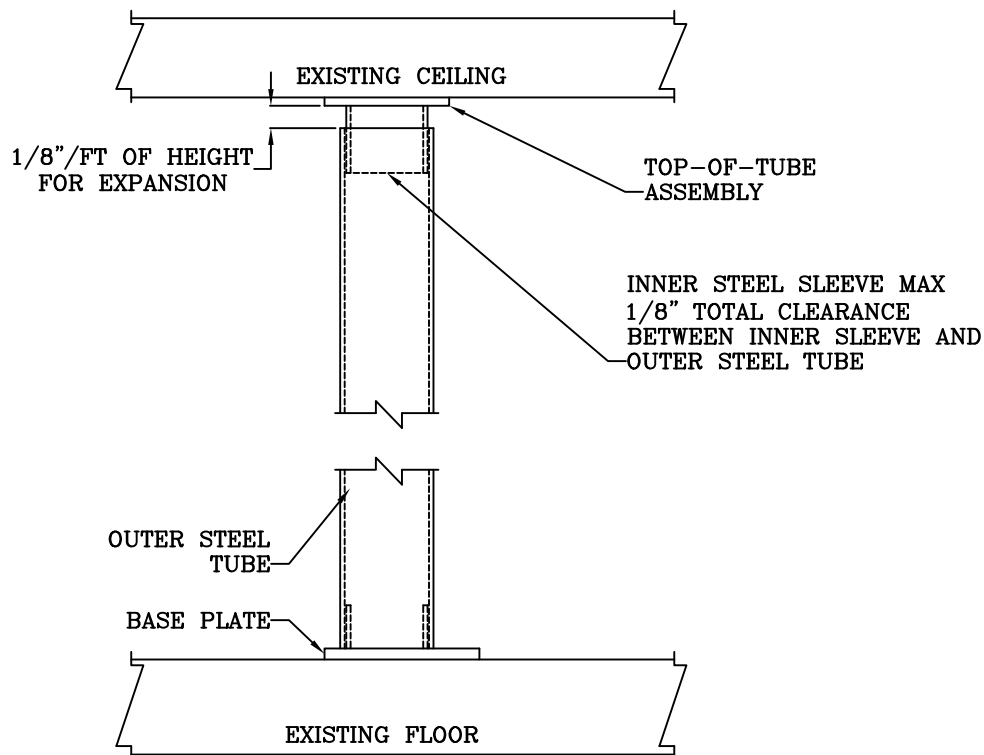

Figure 3
Ceiling and floor mounting



TECHNICAL DATA SHEET

ROLLING STEEL FIRE DOORS BOLTED ONTO STEEL TUBES, SET AGAINST FACE OF FIRE RATED WALLS

Figure 4
Wall and floor
mounting

Figure 5
Wall and floor
mounting

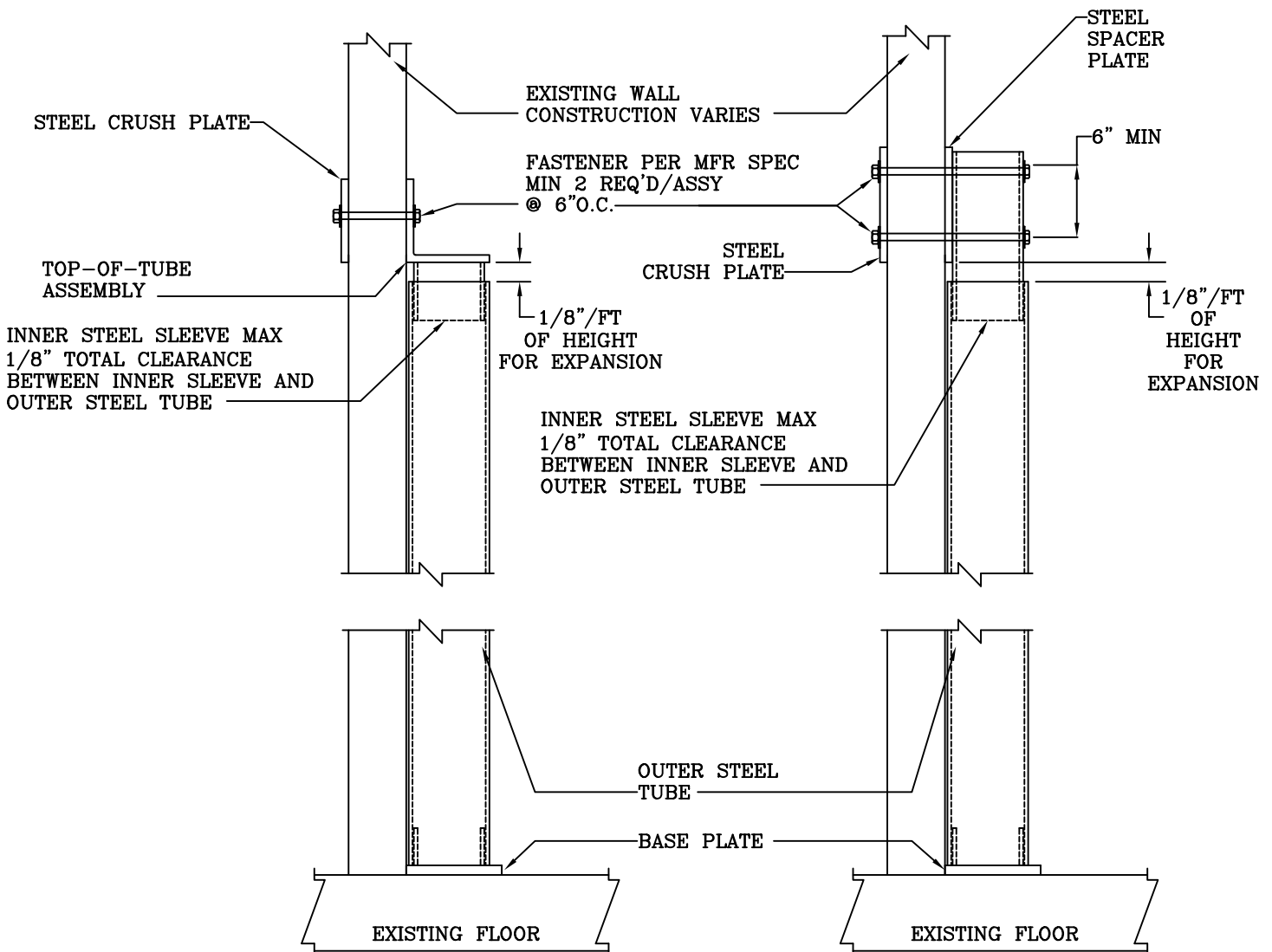

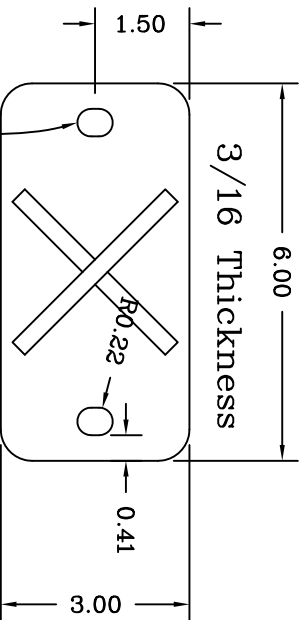
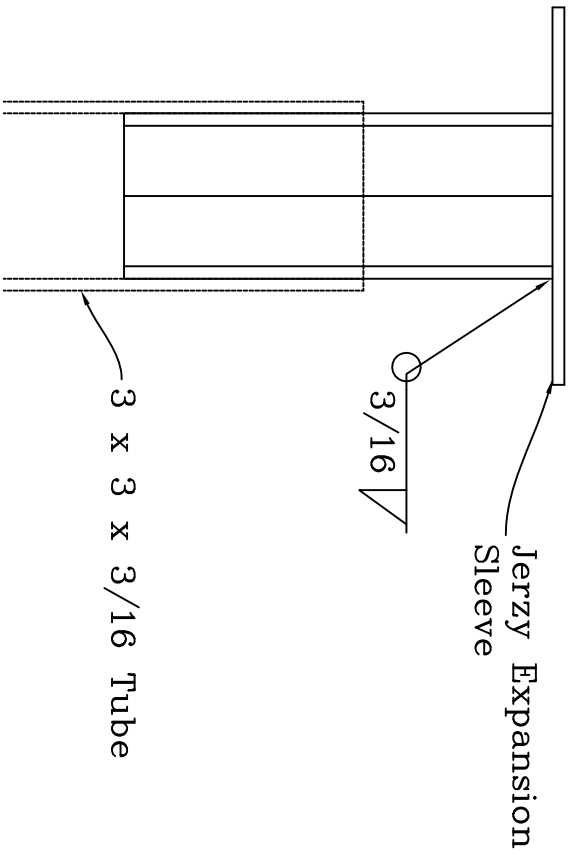

Anchor with (2)
3/8" Bolts

Located at top and bottom
of the 3x3 Tube

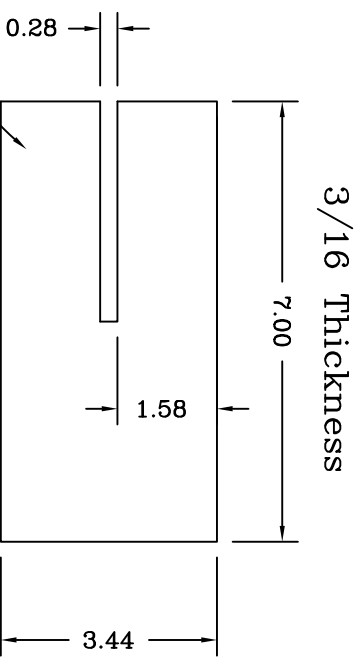
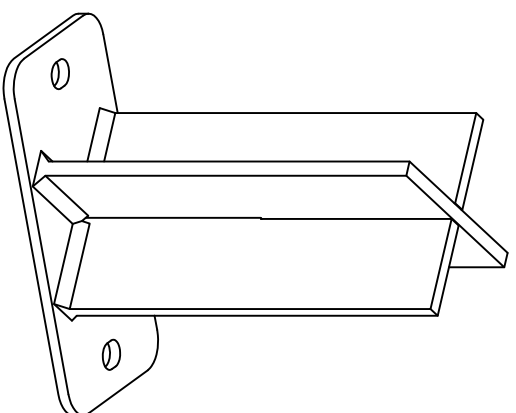

2 pcs. Interlocked to form an "X"

Alpine®		PROJECT:	BASE
OVERHEAD DOORS, INC.		PART#:	JERZEY
8 Hulise Road		SCALE:	SLEEVE
E. Setauket, N.Y. 11733		PAGE #:	NONE
DRAWN BY:	SM		
DATE:	2/2/2000		