

# FIRE DOOR

# Insulated Flat Slat



Motor Operated  
Face of Wall Mounted

Page#:

Page 1

- LG - Left Guide
- RG - Right Guide
- B - Bracket
- GW - Guide Width
- GD - Guide Depth

**NOTE: Redi-Reset Hand Motor Only.**

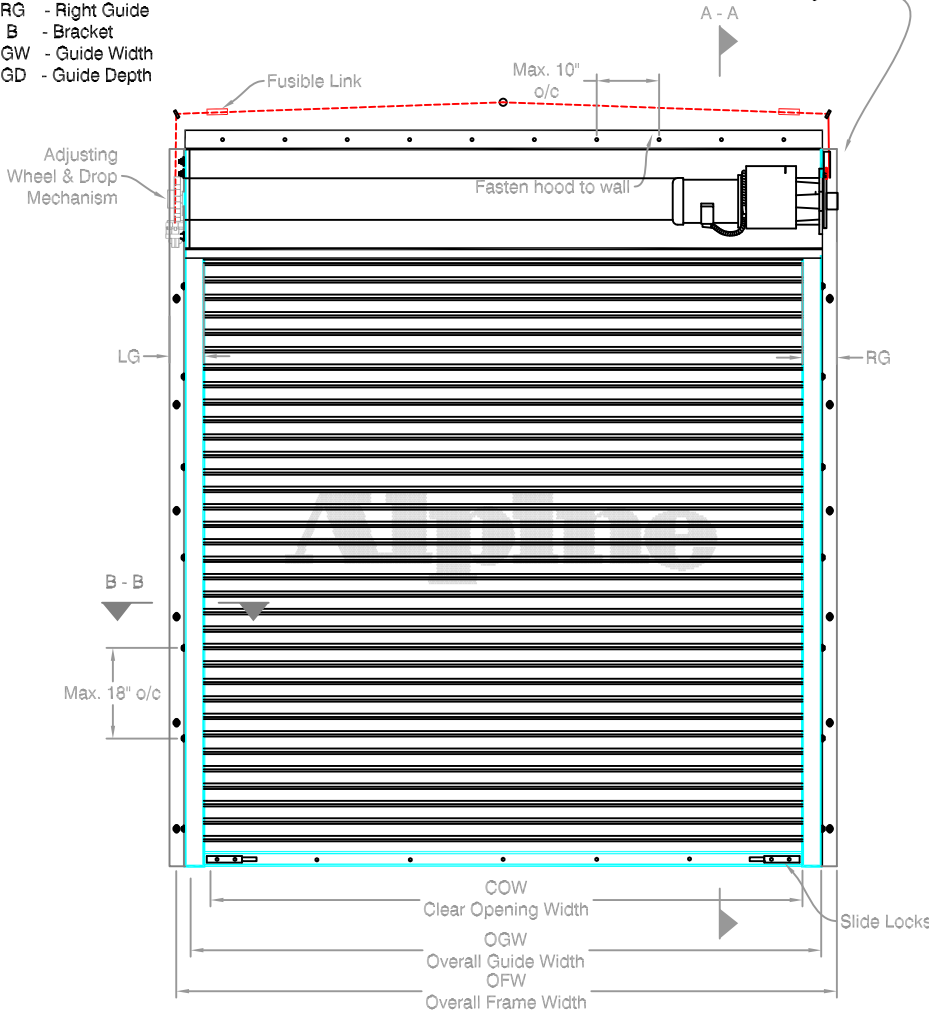

**COIL SIDE ELEVATION**

**NOTE:** The Non-Fail Safe Redi-Reset motor is equipped with a hand chain. The Fail Safe Redi-Reset motor is not equipped

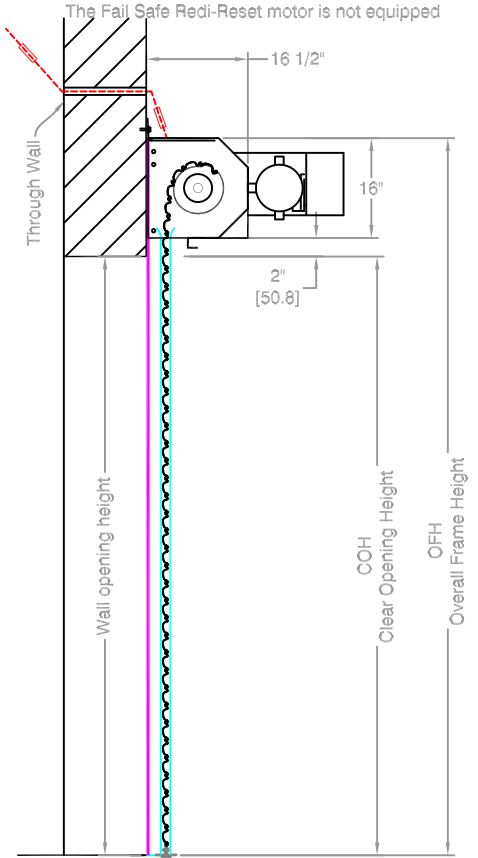

**VERTICAL SECTION A - A**

**FACE MOUNTED TO MASONRY**

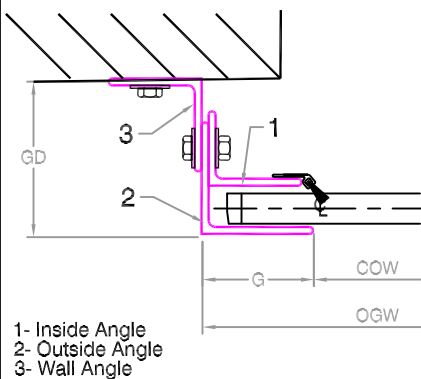

**FACE MOUNTED TO STEEL**

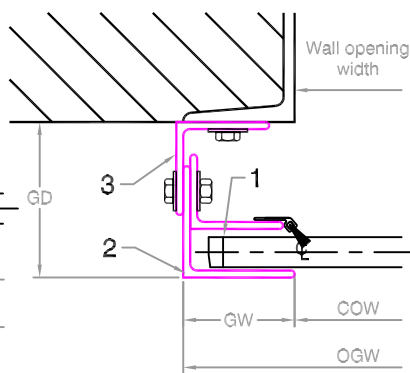

**FACE MOUNTED TO TUBE**

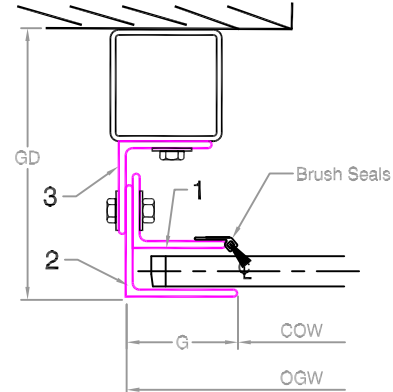

- 1- Inside Angle
- 2- Outside Angle
- 3- Wall Angle

**GUIDE SECTION B - B**

**Notes:**

- 1. See Page 2 for more options.
- 2. All metric conversions of dimensions are shown in brackets [ ].

SALES REP:

CUSTOMER:

JOB NAME:

NUMBER:

Manufactured by:



8 HULSE ROAD EAST SETAUKET, N.Y. 11733

TEL: (631)473-9300 FAX: (631)642-0800

© COPYRIGHT FEB. 2005

# FIRE DOOR

# Insulated Flat Slat



Motor Operated  
Face of Wall Mounted

Page#:

Page 2

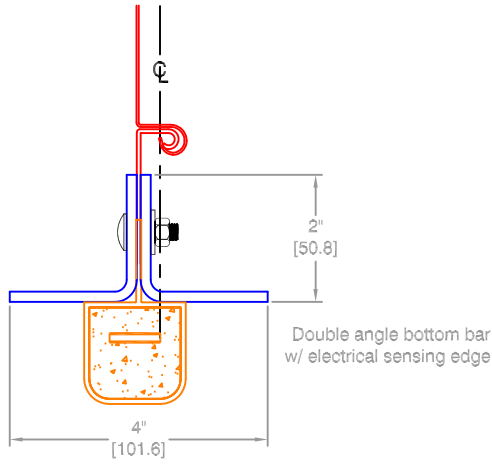

**BOTTOM BAR DETAIL**

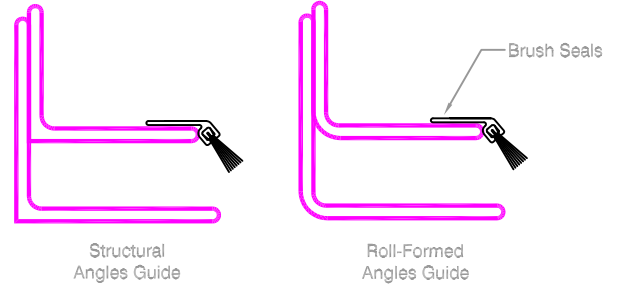

**GUIDE OPTIONS**

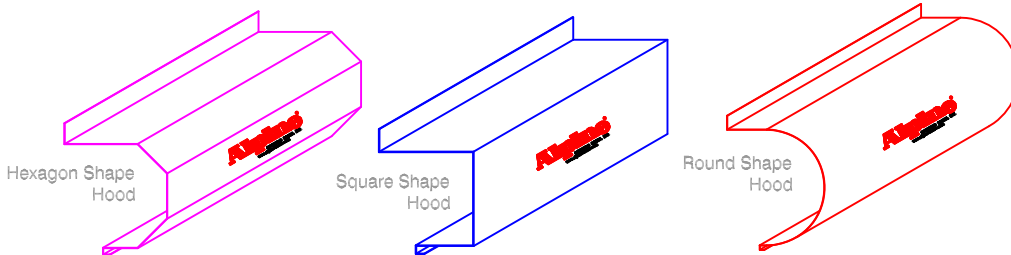

**HOOD SHAPES AVAILABLE FOR THIS DOOR**

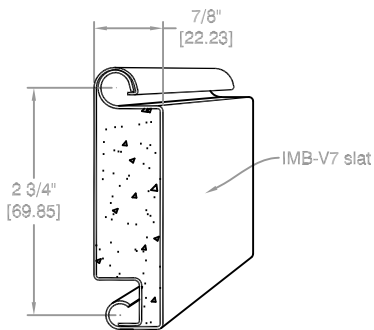

**SLAT OPTIONS**

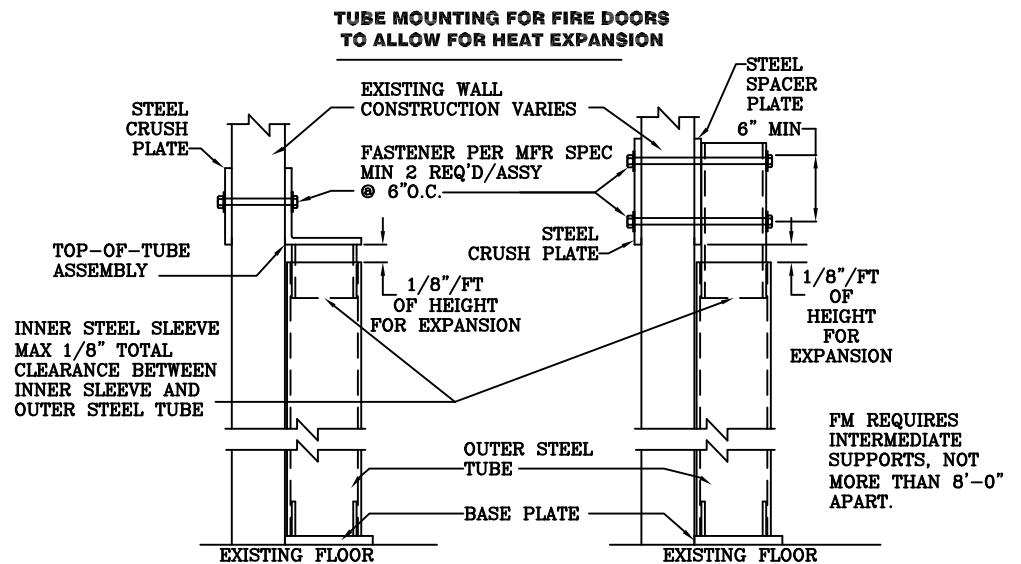

Distributed By:

Call your Alpine representative for additional options and safety products to help find the best Alpine door to suit your needs.

Manufactured by:

**Alpine**<sup>®</sup>  
OVERHEAD DOORS, INC.  
8 HULSE ROAD EAST SETAUKET, N.Y. 11733  
TEL: (631)473-9300 FAX: (631)642-0800  
© COPYRIGHT MAY 2007

# FIRE DOOR

# Insulated Flat Slat

NOTE: MAXIMUM PIPE DEFLECTION ON ANY SIZE DOOR IS .034



Page#:

Page 3

Finding the minimum required operation for the size door you need.

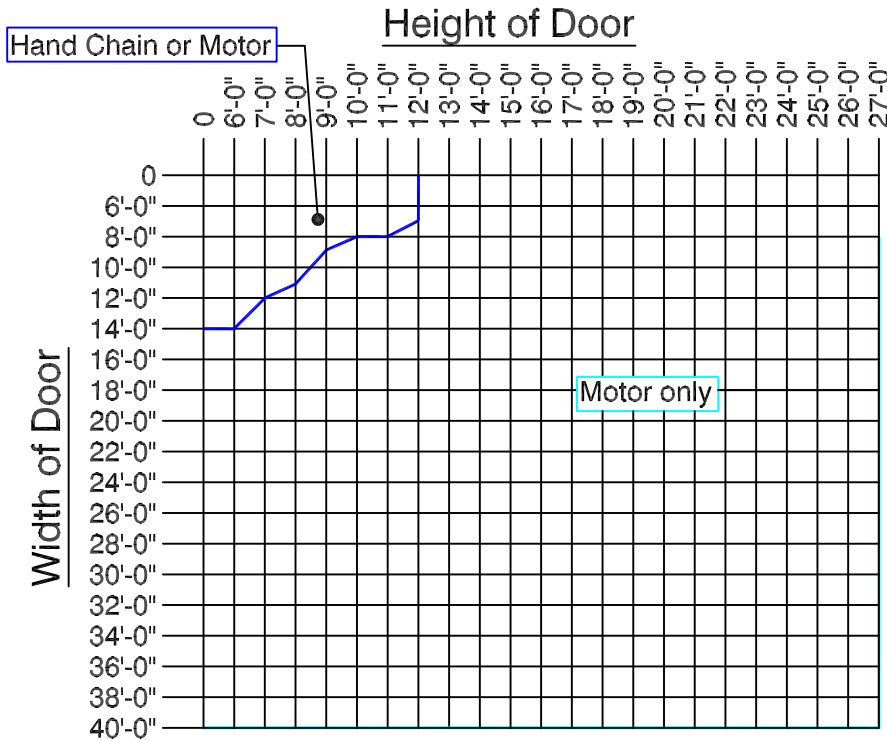

## Operator Legend

— Hand Chain Operation

— Motor Operation Only

To use Chart: Find where your door width and height meet to find the minimum operation that may be used for that door size.

For example: The blue line indicates a Hand Chain Operation. Any size door on that line or above that line may use a Hand Chain, including the door sizes that fall into the Manual push up door. But, The Manual push up door may not be used for any door size below the line representing Push up operation. For any door size larger than what is represented here please consult your Alpine Overhead Doors, Inc. Factory. This Graph is for reference only, subject to change without notice.

Finding the minimum required bracket size for the door you need.

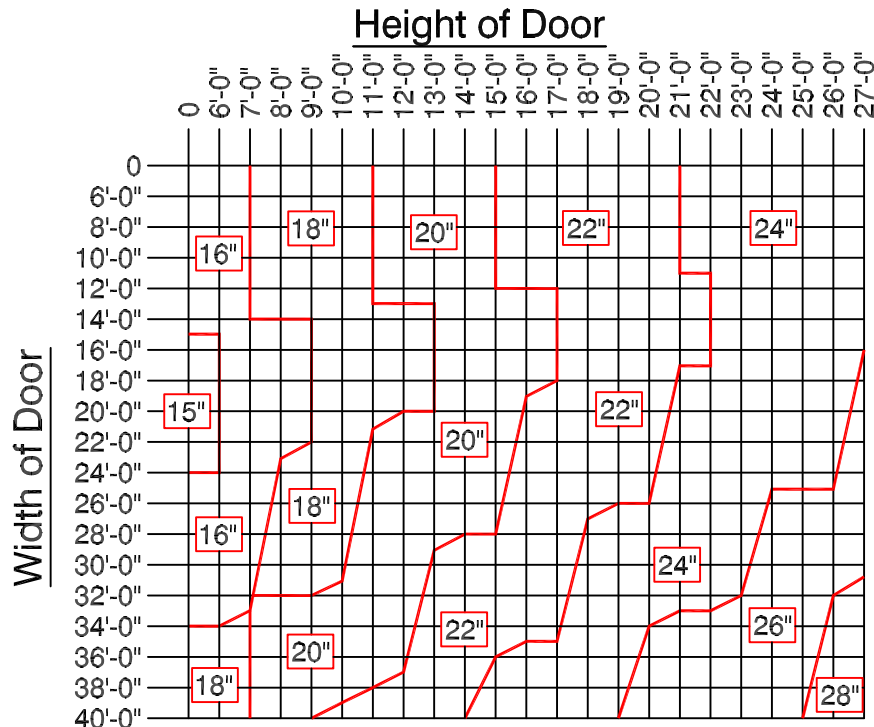

NOTE: Bracket sizes may vary based on gauge of curtain. Bracket size is directly related to the pipe low moment arm deflection (not more than .03 inches per foot).

To use Chart: Find where your door width and height meet to find the minimum bracket size for your door. For any door size larger than what is represented here please consult your Alpine Overhead Doors, Inc. Factory. This Graph is for reference only, subject to change without notice.

Distributed By:

Manufactured by:



8 HULSE ROAD EAST SETAUKET, N.Y. 11733  
 TEL: (631)473-9300 FAX: (631)642-0800  
 © COPYRIGHT DEC 2006