

Counter-Shutter Fire Door



AUTO FIRE SHUT
COUNTER-SHUTTER FIRE DOOR

Hand Chain Operated
Face of Wall Mounted

Page#:

Page 1

LG - Left Guide
RG - Right Guide
B - Bracket
GW - Guide Width
GD - Guide Depth

NOTE: Redi-Reset Hand Chain Only.

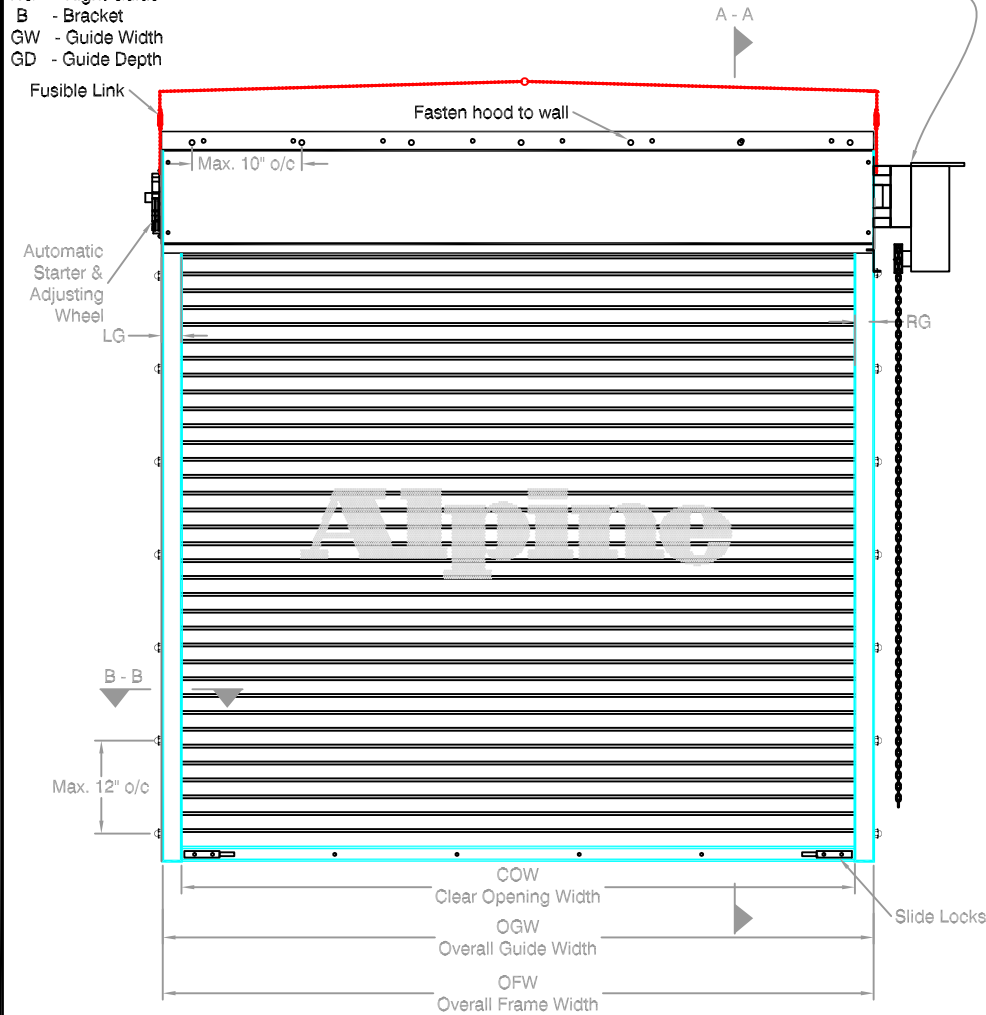

COIL SIDE ELEVATION

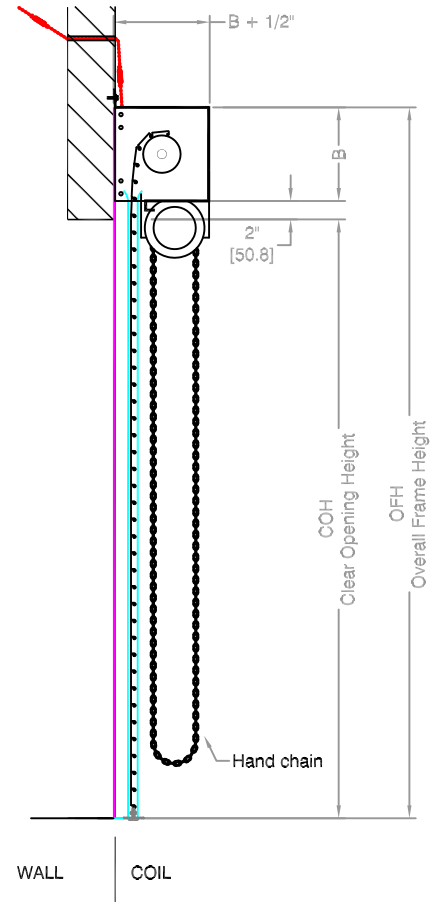

VERTICAL SECTION A - A

FACE MOUNTED TO MASONRY

FACE MOUNTED TO STEEL

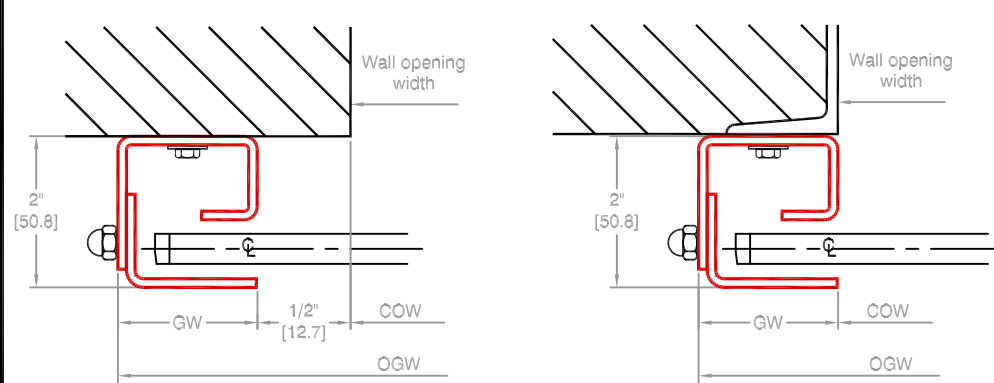

GUIDE SECTION B - B

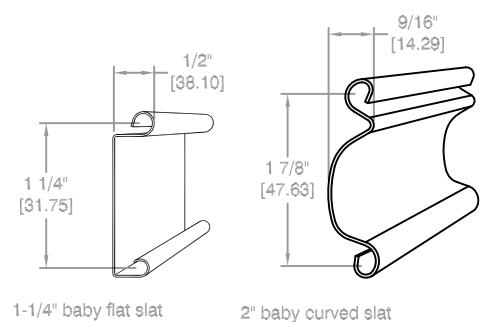

SLAT OPTIONS

CURTAIN DETAIL

Notes:

1. See page 2 for more options,
2. All metric conversions of dimensions are shown in brackets [].

SALES REP:

CUSTOMER:

JOB NAME:

NUMBER:

Manufactured by:



8 HULSE ROAD EAST SETAUKET, N.Y. 11733
TEL: (631)473-9300 FAX: (631)642-0800
© COPYRIGHT MAY 2007

Counter-Shutter Fire Door

AUTO FIRE SHUT
COUNTER-SHUTTER FIRE DOOR

Hand Chain Operated
Face of Wall Mounted

Page#:

Page 2

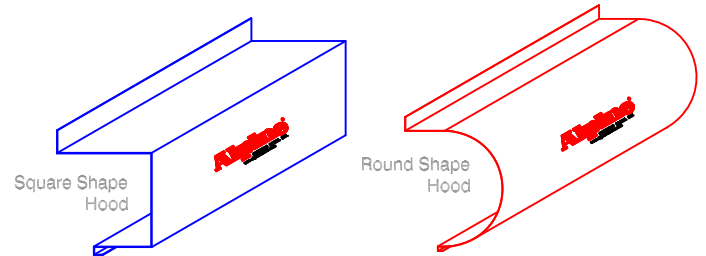
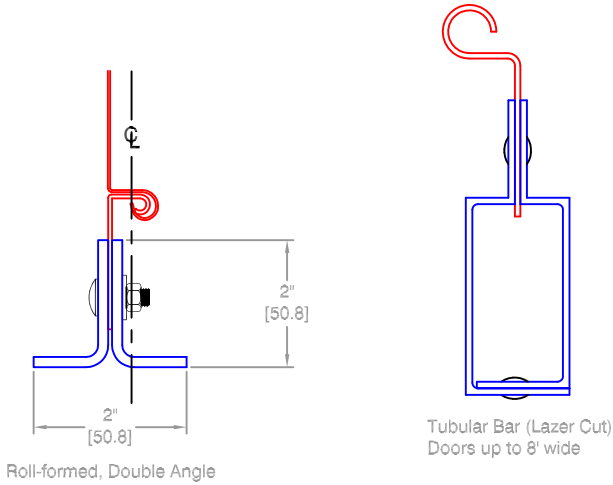

BOTTOM BAR OPTIONS

HOOD SHAPES AVAILABLE FOR THIS DOOR

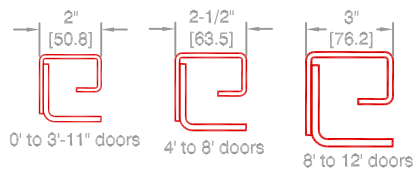

"G" Shutter Guide

GUIDE DETAIL

TUBE MOUNTING FOR FIRE DOORS TO ALLOW FOR HEAT EXPANSION

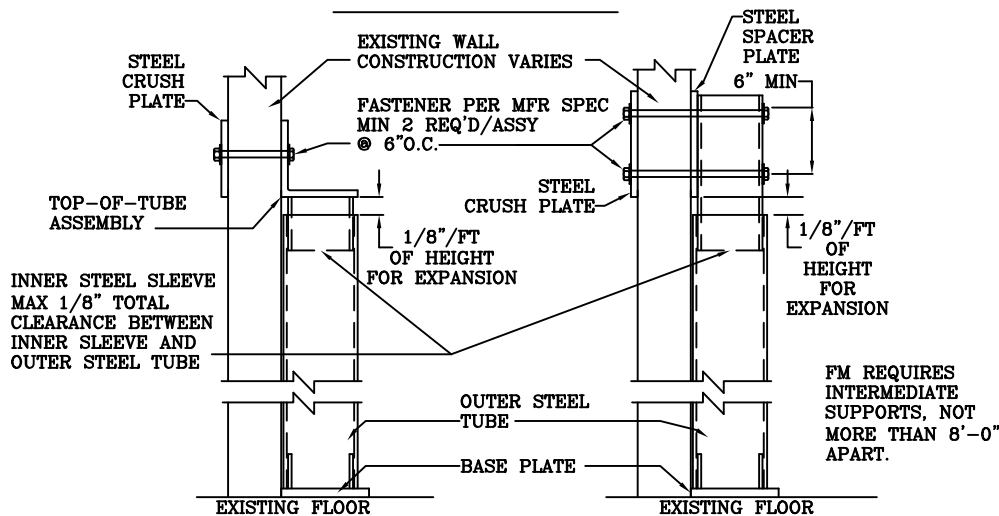

Distributed By:

Call your Alpine representative for additional options and safety products to help find the best Alpine door to suit your needs.

Manufactured by:

Alpine[®]
OVERHEAD DOORS, INC.
8 HULSE ROAD EAST SETAUKET, N.Y. 11733
TEL: (631)473-9300 FAX: (631)642-0800
© COPYRIGHT MAY 2007

NOTE: MAXIMUM PIPE DEFLECTION ON ANY SIZE DOOR IS .034



Page#:

Page 3

Finding the minimum required operation for the size door you need.

Height of Shutter

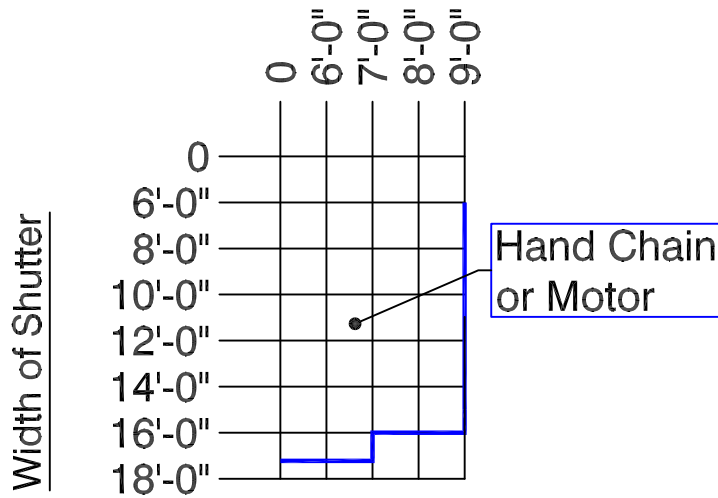

FOR LARGER SIZES CONSULT FACTORY.

Operator Legend

- Hand Chain Operation
- Motor Operation Only

To use Chart: Find where your door width and height meet to find the minimum operation that may be used for that door size.
 For example: The blue line indicates a Hand Chain Operation. Any size door on that line or above that line may use a Hand Chain, including the door sizes that fall into the Manual push up door. But, The Manual push up door may not be used for any door size below the line representing Push up operation. For any door size larger than what is represented here please consult your Alpine Overhead Doors, Inc. Factory. This Graph is for reference only, subject to change without notice.

Finding the minimum required bracket size for the door you need.

Height of Shutter

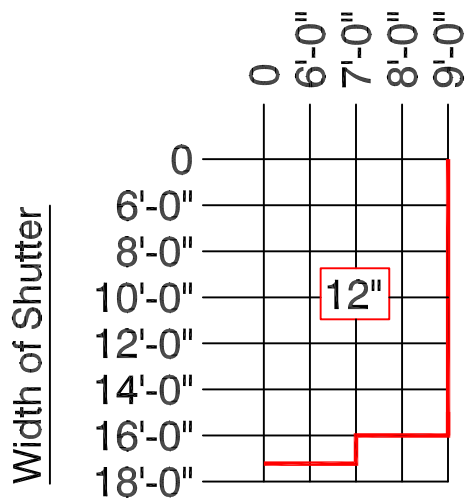

FOR LARGER SIZES CONSULT FACTORY.

NOTE: Bracket sizes may vary based on gauge of curtain. Bracket size is directly related to the pipe low moment arm deflection (not more than .03 inches per foot).

To use Chart: Find where your door width and height meet to find the minimum bracket size for your door. For any door size larger than what is represented here please consult your Alpine Overhead Doors, Inc. Factory. This Graph is for reference only, subject to change without notice.

Distributed By:

Manufactured by:



8 HULSE ROAD EAST SETAUKET, N.Y. 11733
 TEL: (631)473-9300 FAX: (631)642-0800
 © COPYRIGHT DEC 2006

NOTE: MAXIMUM PIPE DEFLECTION ON ANY SIZE DOOR IS .034



Page#:

Page 3

Finding the minimum required operation for the size door you need.

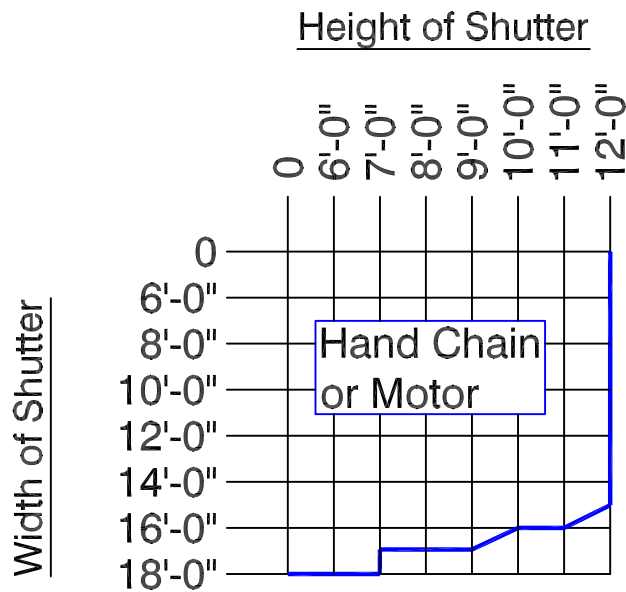

FOR LARGER SIZES CONSULT FACTORY.

Operator Legend

— Hand Chain Operation

— Motor Operation Only

To use Chart: Find where your door width and height meet to find the minimum operation that may be used for that door size.

For example: The blue line indicates a Hand Chain Operation. Any size door on that line or above that line may use a Hand Chain, including the door sizes that fall into the Manual push up door. But, The Manual push up door may not be used for any door size below the line representing Push up operation. For any door size larger than what is represented here please consult your Alpine Overhead Doors, Inc. Factory. This Graph is for reference only, subject to change without notice.

Finding the minimum required bracket size for the door you need.

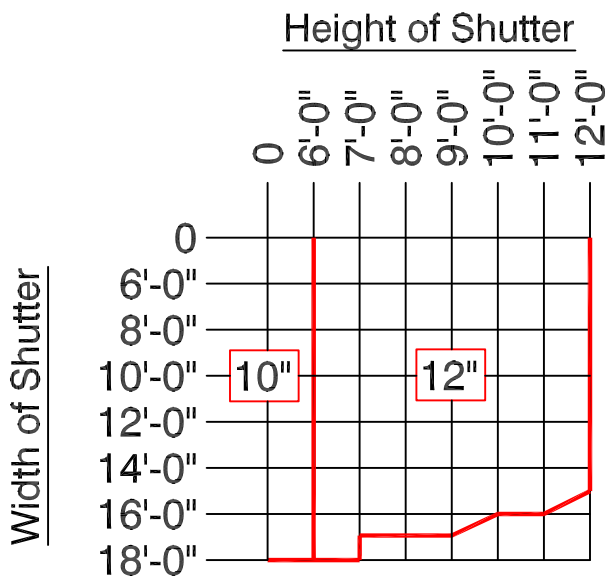

FOR LARGER SIZES CONSULT FACTORY.

NOTE: Bracket sizes may vary based on gauge of curtain. Bracket size is directly related to the pipe low moment arm deflection (not more than .03 inches per foot).

To use Chart: Find where your door width and height meet to find the minimum bracket size for your door. For any door size larger than what is represented here please consult your Alpine Overhead Doors, Inc. Factory. This Graph is for reference only, subject to change without notice.

Distributed By:

Manufactured by:



8 HULSE ROAD EAST SETAUKET, N.Y. 11733
 TEL: (631)473-9300 FAX: (631)642-0800
 © COPYRIGHT DEC 2006