



FIRE-TITE
INSTALLATION
INSTRUCTIONS

INSTALLATION INSTRUCTIONS



These installation instructions are clearly to assist you with the installation of Alpine Fire doors ONLY. Do NOT use these instructions to install doors other than Alpine. Only an experienced installer should install these doors



FIRE STORM rolling steel fire doors are built to sizes according to what is given. Material and parts may change in sale or design depending on door sizes

STEP 1

Measure opening size and verify drawing dimensions. Identify wall angles by vertically slotted holes. The holes to be bolted to wall will be between 12" and 18" apart. Set angles in place on both sides of opening. The angles must be set 1/2" above the floor to allow for expansion; they also must be held. Fasten to wall using thru bolts on masonry walls or drill and tap to steel jambs. DO NOT WEL .

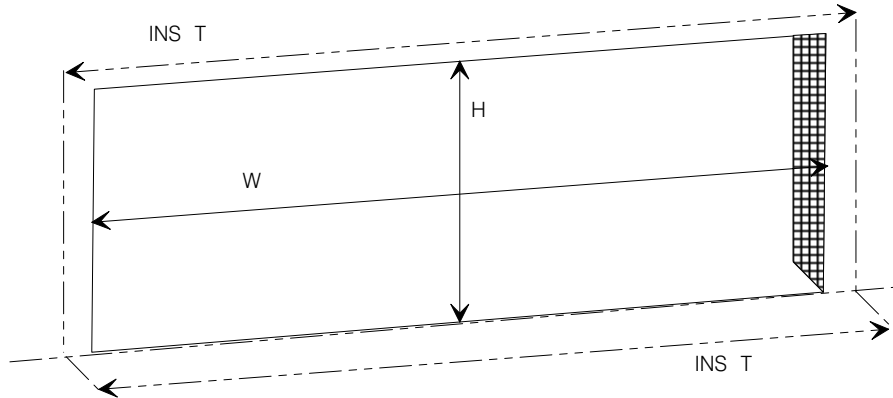

STEP 2

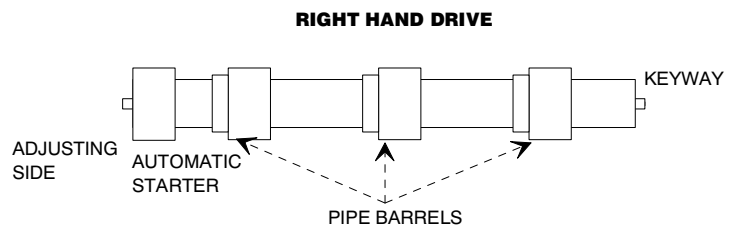
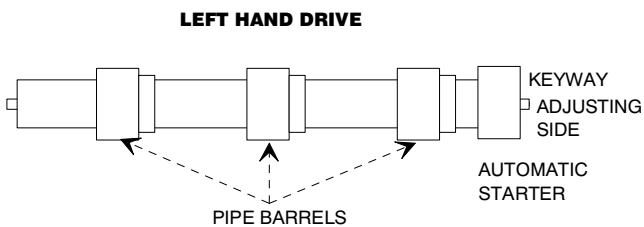
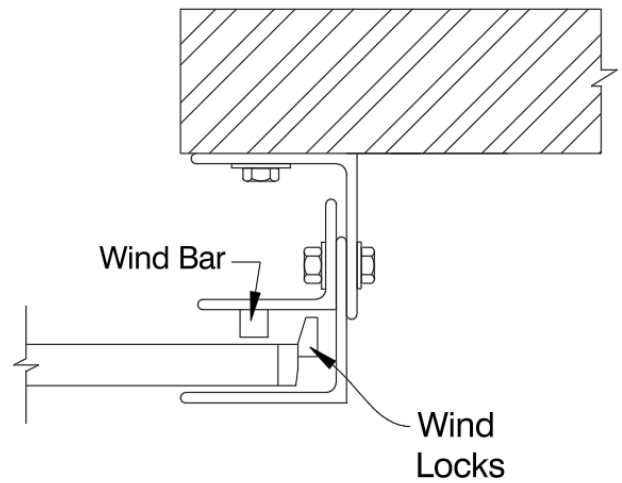
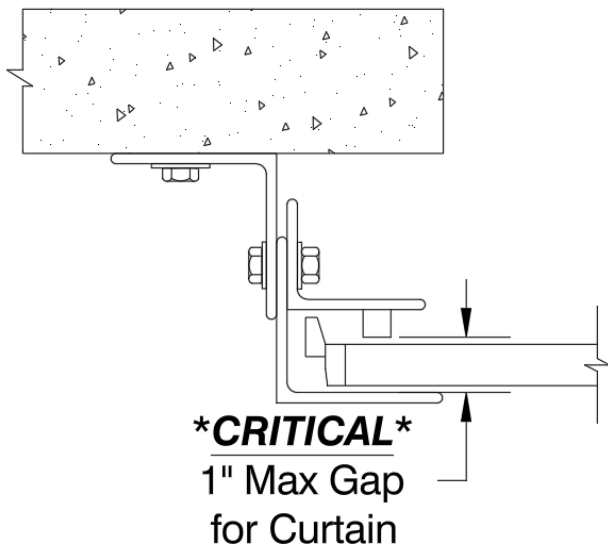

Alpine® OVERHEAD DOOR

FI -TIT
INSTALLATI N
INST UCTI NS

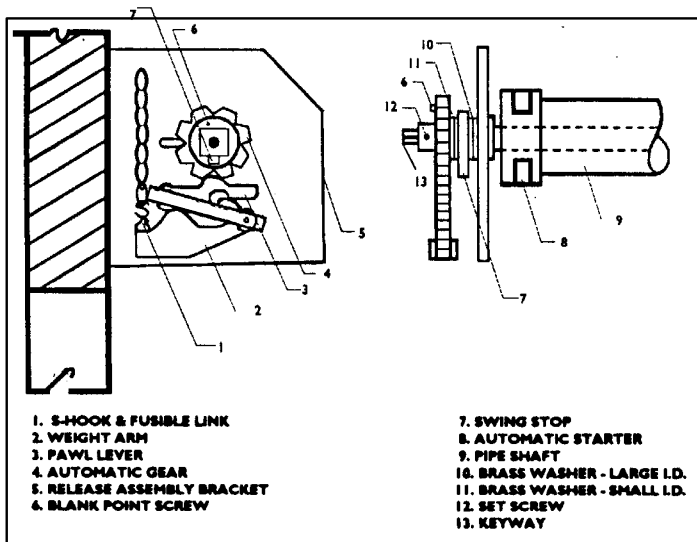

ST P 3

Place a chain block over center of opening and raise pipe off floor enough to slide brackets on shaft first. Slip automatic adjusting bracket onto shaft first, followed by large I.D. brass washer, swing stop, then smaller brass washer.

Remove weighted pawl by removing "S" hook from bracket, then replace spring tension gear making certain to replace it the same way it was taken off. Drive keyway into gear hub and shaft and secure with set screw. Back out blank point hex screw on adjusting shaft and secure with set screw.

ST P 4

Place drive bracket on keyed end of shaft, making sure that governor star wheel is properly set with key stock. For chain or motor operated door, the 1" gear is then slipped into mesh with smaller gear. Note: make sure that gears are spaced correctly. Star gear must be in line with governor ring. 1" gear should be properly aligned to shaft using square key and set 1/8" gear with set screw. In motor operated door, motor mounting plate and assembly should be installed at this time. Thru bolt motor mounting plate to masonry wall then attach motor unit to plate and connect drive chain to 1" tooth sprocket on drive bracket. Raise pipe shaft up, with the brackets attached, into position above opening and bolt brackets to outside of wall angles using flat head bolts on counter sunk holes. Then level pipe using a spirit level. Adjust wall angles up or down to level.

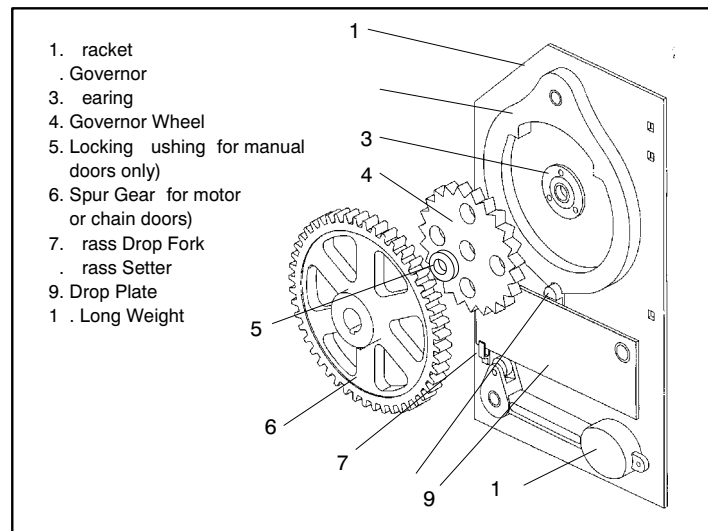

ST P 5

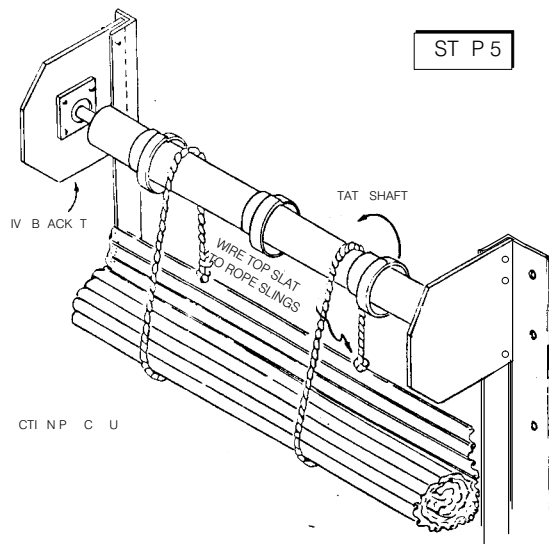

Hoist coiled curtain to about 1 foot below pipe and suspend from rope using rope slings. Note: Be sure that adjusting gear is disengaged during the next step to avoid building up tension on springs. Coil the curtain up and over the pipe by hand. The slings will rotate, carrying the top slat over. Align top slat with barrel rings and punch holes in top slat, then bolt to pipe barrels. Continue to roll curtain onto shaft until bottom bar of curtain is about one foot from bottom brackets. Untie the rope slings. Caution: Make sure to secure the curtain from unrolling.

STEP 6

Secure the tracks with bell mouths onto the wall angles using 3/8" bolts, washers and nuts, maintaining at least 1 1/8" spacing between inner and outer guide angles to allow curtain to move up and down freely. Put tension on springs using a large stillson type wrench on the hub of the automatic adjusting gear. The weight and pawl can be raised to hold the gear while the wrench is repositioned. Put on enough tension so that the door stays up by itself. Lock adjusting gear by attaching "S" hook to stud on bracket. Operate door several times to limber up curtain and bearings. Adjust tension, if necessary.

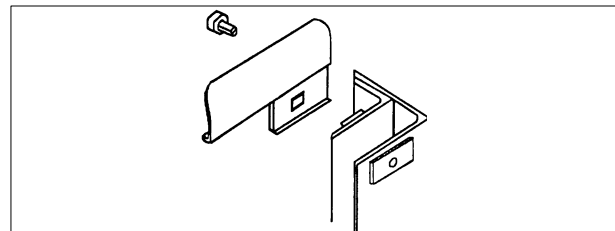
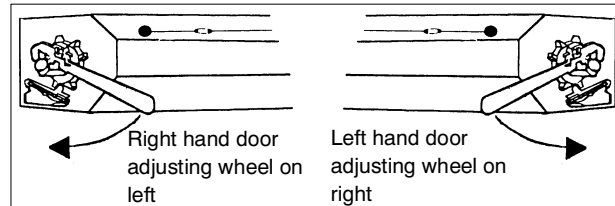

STEP 7

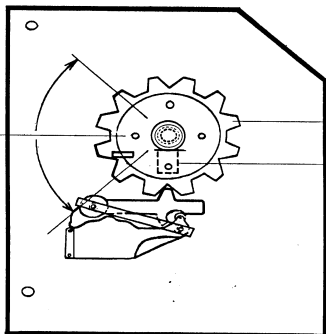

Position hex blank point screw in adjusting gear so that it will allow 7/8 to 1 revolution of wheel when pawl is released. Chalk mark gear and drop test door by removing both fusible links at the same time. Make sure doorway is clear of any obstructions. Door should travel all the way to floor under its own power. Reset adjusting gear in original position.

STEP 8

Next, install hood by punching holes in the sheet metal and bolting to flanges on brackets using self tapping screws. Then set two eye bolts into wall above each side of the door using 5/16" shields. Rig copper sash chain through eyebolts and hook up fusible link over center of the door along with 1 turnbuckle for adjustment. Attach this to links already on brackets. Make sure that if any one fusible link melts, weights on both brackets will fall out of engagement with gears. Lightly grease guides and gear assembly.

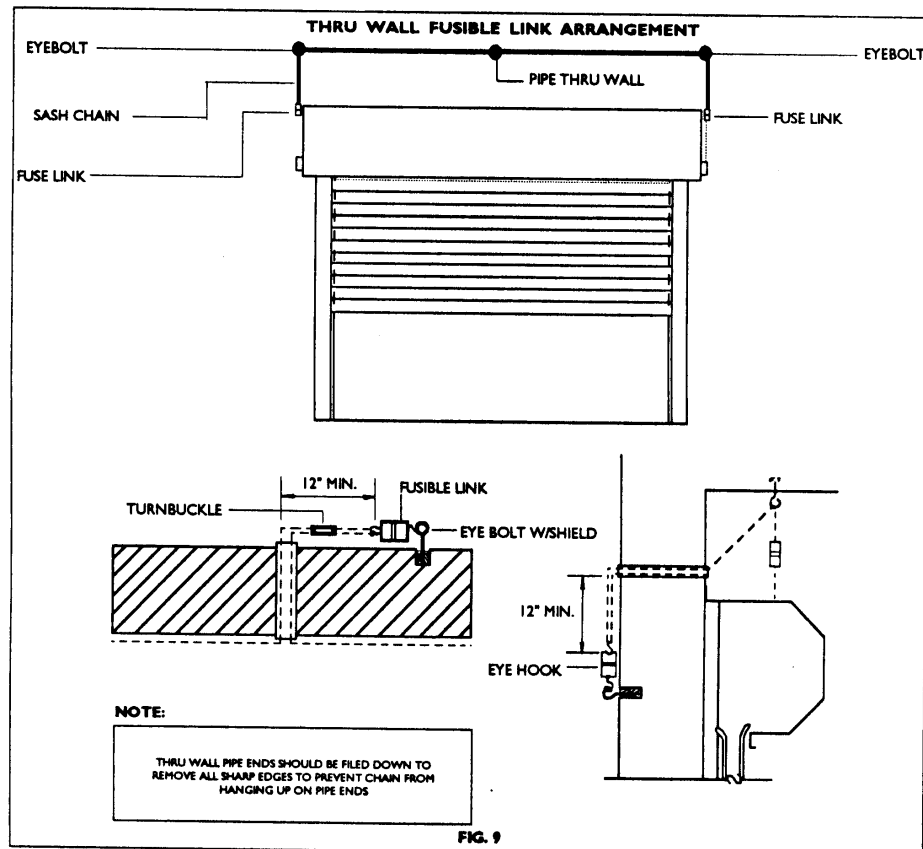



MAINTENANCE INSTRUCTIONS

LUBRICATION

The most important single maintenance item on doors of this type is lubrication. This is required only at certain points because all rotating members are equipped with high quality sealed bearings that are lubricated for life.

The curtain guides and the teeth of the gears contained in chain hoist or hand crank mechanism (if supplied) should be lubricated at least twice a year (more often if door works very frequently) with one of the following greases:

- Dixon's #2 Graphite Cup Grease (#1 for summer weather)
- Alemite MP Lithium Grease (#1 for winter weather, #2 for normal)
- Texaco #904 Graphite Grease, or other equivalents

If door is electrically operated, check the oil level in the worm gear speed reducer every six months and replenish if necessary with S.A.E. 140 gear oil for normally heated buildings or thinner grades for outside installations exposed to low temperatures.

PAINT:

All non-lubricated steel surfaces should be painted annually (more often if required in corrosive atmospheres) with a good grade of rust inhibiting metallic base paint.

SPRING ADJUSTMENT:

In time, the counter balancing springs may lose some of their initial tension; this condition imposes an extra load on the operator and should be corrected as follows.

- a) manually operated doors should be opened fully by hand and held open by "C" clamps or vise grip pliers on each guide.
- b) Mechanically operated doors should be opened fully and the crank or hand chain should be locked to hold the door open.
- c) electrically operated doors should be open fully by pushing the UP or OPEN button; motor brake will hold the door open. Shut off power supply to the motor during adjustment.
- d) with a suitable tool (18" or 24" pipe wrench or larger spanner) turn the spring adjusting wheel (1/8 turn at a time) until the door is balanced properly. Make sure locking pawl is properly engaged in spring adjusting wheel.

NOTE: For door with adjusting wheel on left hand side, wind spring clockwise (downward), for door with adjusting wheel on right hand side, wind spring counterclockwise (downward).



INSPECTION AND DROP TEST GUIDELINES

REFER TO ALPINE'S INSTALLATION/RESET INSTRUCTIONS AND NFPA-80

VISUAL INSPECTION

CAUTION: Every component of a door and it's installation must be checked for determination of factors that may affect a door's intended operation and performance. The list below may be incomplete and is provided as a guideline only.

- A) Proper installation
 - 1) curtain, barrel and guides are aligned, level, plumb and true
 - 2) attachment to jambs with proper bolts, expansion anchors, or as otherwise required by the listing
 - 3) expansion clearance (when required)
 - 4) fusible links locations

- B) Damaged, incorrect or missing parts
 - 1) slats – bent slats, cracked beads, torn ends
 - 2) endlocks – missing, broken, bent, loose
 - 3) bottom bar – bent angles, loose bolts
 - 4) guide assembly – bent angles, loose bolts, missing fiber washers (when required)
 - 5) hood and flame baffle (when baffle required) – bent, rubbing curtain in open position, holes, tears, attachment to brackets and wall (when required), intermediate supports (when required)
 - 6) brackets and operating mechanisms – worn, mis-aligned or badly meshed gears, broken parts, bent shafts
 - 7) automatic closing and governor mechanisms – missing or broken parts, drop or release arms tied, blocked, or wedged
 - 8) fusible link, sash chain/cable, S-hooks, eyes, etc. – links painted or coated with dust or grease, kinked or pinched cable, chain twisted or not flexible, obstructed eyes or raceways
 - 9) mounting and assembly bolts – missing or loose
 - 10) past replacement of parts not from the original door manufacturer – “homemade” or mis-matched parts

- C) Ancillary equipment
 - 1) smoke detectors/release devices – check continuity
 - 2) control panels – check function
 - 3) miscellaneous other equipment should be checked for proper function and operation

OPERATIONAL INSPECTION

Roll door up and down in normal operation to check for spring tension and free movement of curtain in guides.

DROP TEST

If door does not roll up and down properly in normal operation or if there are damaged or missing parts that will create a hazard or prevent proper operation or reset, THESE CONDITIONS SHOULD BE CORRECTED BEFORE CONDUCTING A DROP TEST.

Drop test per Alpine's instructions. Drop test should provide for automatic closing of the curtain at an average speed of not less than 6 inches per second, nor more than 24 inches per second, and full closure of the curtain with the bottom bar resting on the sill.

Reset per Alpine's instructions.

IMPORTANT CHARGE WHEEL BOLT **MUST** BE REPLACED AFTER MULTIPLE DROP TESTS.

ULTIMATE ACCEPTABILITY OF A FIRE DOOR IS THE DECISION OF THE AUTHORITY HAVING JURISDICTION, AS DEFINED BY NFPA-80



OVERHEAD DOORS, INC.

ROLLING FIRE DOOR INSPECTION AND DROP TEST FORM

NOTE TO OWNER: NFPA-80 and Model Codes require annual testing of rolling fire doors and demonstrate proper operation and full closure. Resetting of the release mechanism must be done in accordance with the manufacturer's instructions. A written record must be maintained and made available to the authority having jurisdiction. NFPA-80 also requires that when damage impairs the door's proper emergency function that it be repaired with parts obtained from the original door's manufacturer and upon completion of repairs that the door be tested to assure emergency operation and closing.

WARNING: Severe injury or death may result through improper attempts at drop testing, repair and/or maintenance. Drop testing, repair and/or maintenance should be performed by qualified personnel with a complete knowledge and understanding of this type of door. Before drop testing, conduct a visual inspection for damages or missing parts that may create a hazard during testing or affect proper operation or resetting. Verify proper installation. Open and close the door to check for correct spring tension. ADDITIONAL INFORMATION ON DROP TESTING IS PROVIDED ON THE REVERSE SIDE OF THIS FORM, IN THE MANUFACTURER'S INSTALLATION/RESET INSTRUCTIONS AND IN NFPA-80.

PROJECT CONTACT ADDRESS PHONE DATE

Table with columns: LOCATION, SIZE, MANUFACTURER, DOOR SERIAL NO., VISUAL CHECK (PASS/FAIL), OPERATION CHECK (PASS/FAIL), DROP TEST (PASS/FAIL)

RECOMMENDED WORK

The doors listed above have been installed in accordance with the manufacturer's installation instructions. The automatic release device has been tested to demonstrate proper operation and full closure. They have been reset in accordance with the manufacturer's reset instructions and left in proper working condition, unless otherwise noted above.

TESTED BY COMPANY ADDRESS SIGNATURE DATE WITNESSED BY REPRESENTING SIGNATURE RECOMMENDED WORK IS: AUTHORIZED DECLINED BY

SUGGESTED INSPECTION AND DROP TEST GUIDELINES ON REVERSE SIDE

APPENDIX A - NFPA 80

IMPORTANT:

ALWAYS REFER TO NFPA 80, CHAPTER 4, SECTION 4.8.6 AND NFPA 80, CHAPTER 11, SECTION 11.4.3.1.7. SEE DIAGRAMS BELOW FOR REFERENCE TO THESE SECTIONS.

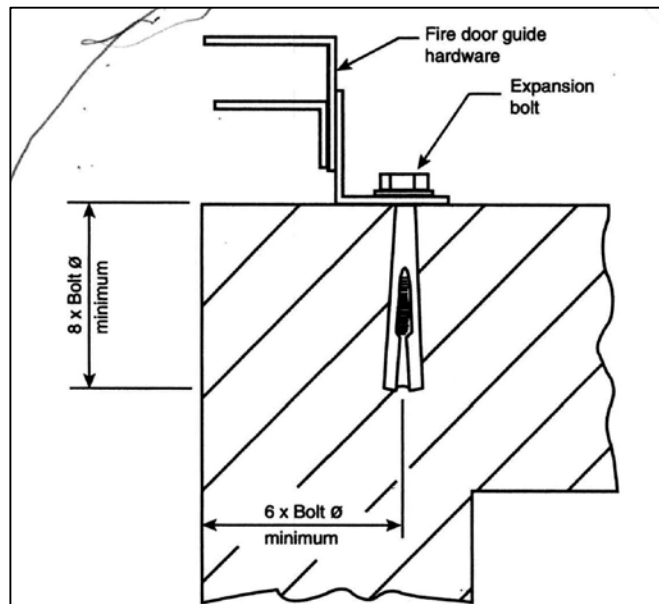

Figure B-9 Corner walls.

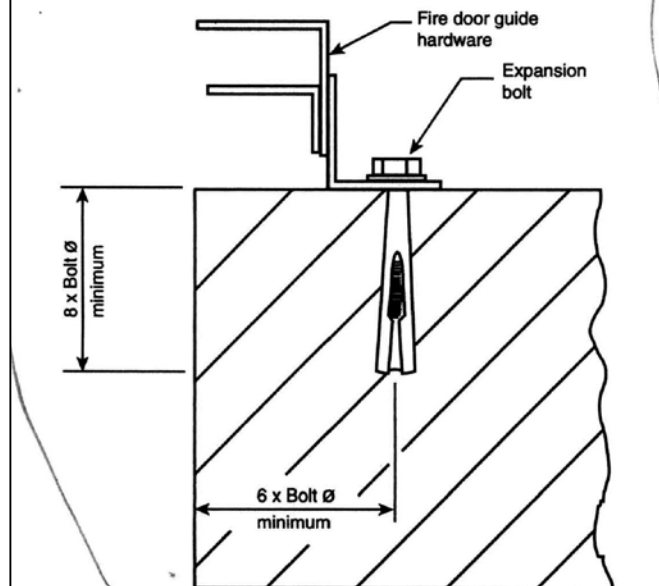

Figure B-10 Unusually thick walls.